

## 微型节流阀

微型节流阀调节气缸内活塞杆的运动速度。

根据 C 型微型节流阀（安装在气缸气口处）和 V 型微型节流阀（安装在阀的输出口处）的配置，气体在供气时流量不受限制，而排气时的流量则受到调节控制。B 型（双向调节型）可调节进气和排气流量。

Metal Work 麦特沃克 MFR 微型节流阀上的调节旋钮有三种调节方式：手动操作（圆螺母外表面滚花）、螺丝刀（插在螺帽的沟槽内）及使用六边形扳手。即使安装完毕后也可调整 MRF 阀体的插管方向。

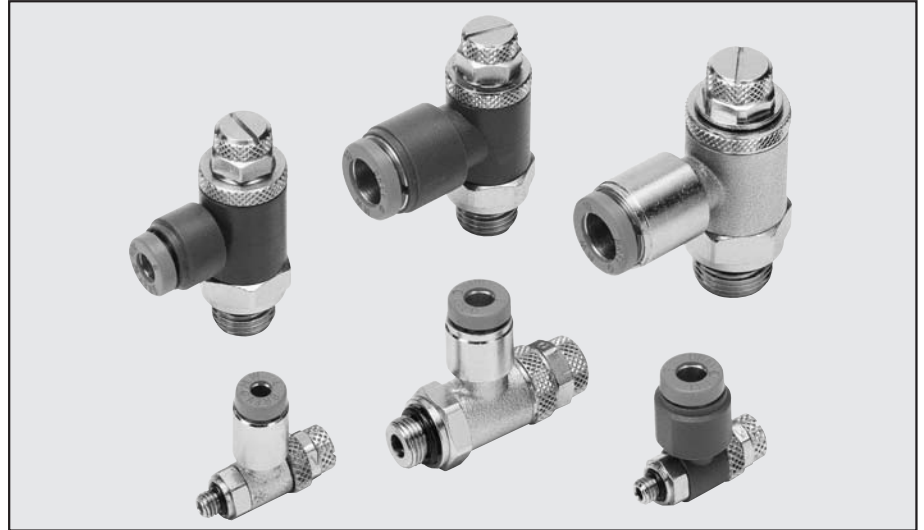

技术参数	M5			1/8"				1/4"				3/8"		1/2"
管径	Ø4	Ø5	Ø6	Ø4	Ø5	Ø6	Ø8	Ø6	Ø8	Ø10	Ø12	Ø10	Ø12	Ø12
阀体上的螺纹	M5			1/8"				1/4"				3/8"		1/2"
最大进气压力	MPa													
	1													
	bar													
	10													
	psi													
	145													
6 bar 调节时的最大流量	95			340				600				870		1400
工作介质	过滤压缩空气，润滑或未润滑。													
工作温度：高分子聚合材质阀体	°C													
	-10° - +50°													
	°F													
	+14° - +122°													
黄铜阀体	°C													
	-10° - +70°													
	°F													
	+14° - +158°													

## 零部件

- ① 调节旋钮：黄铜
- ② 圆形螺母，用于固定调节旋钮或阀体（黄铜）
- ③ 阀芯座：黄铜
- ④ 阀杆：黄铜
- ⑤ 高分子聚合材质插件，流量调节处
- ⑥ 阀体：黄铜或高分子聚合材质
- ⑦ 密封圈：NBR

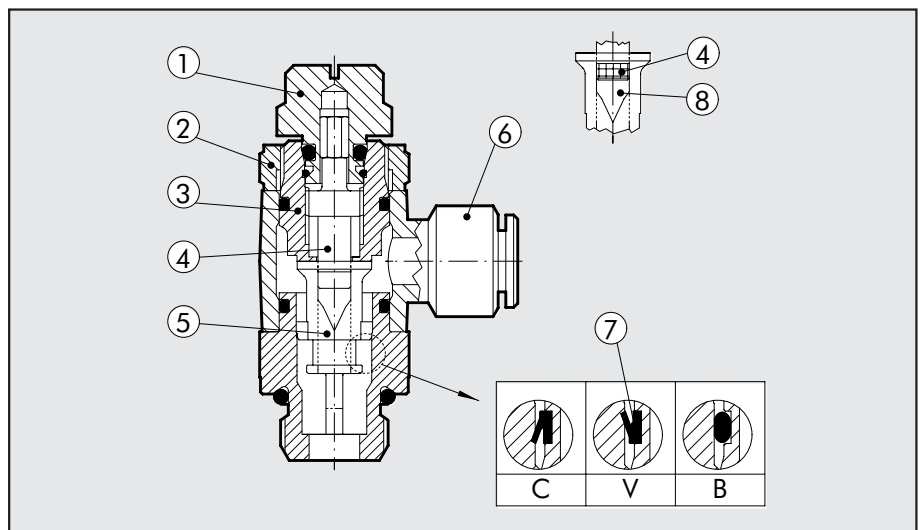



# 流量图

MRF M5

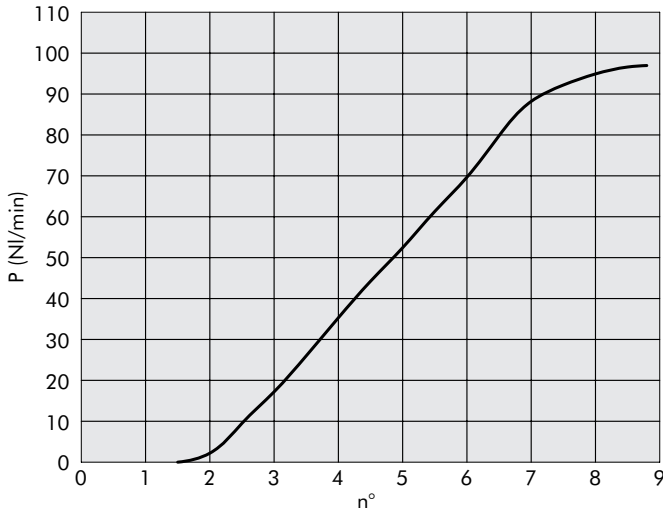

Ø6 管径的流量

MRF G 1/8"

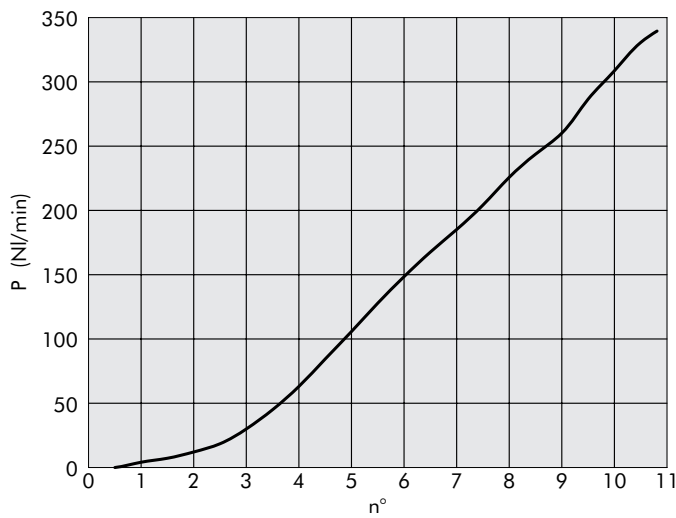

Ø6管径的流量

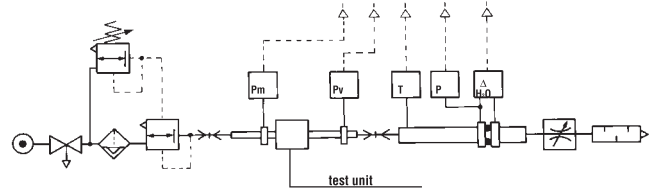

- 都灵工业大学机械系根据 CETOP RP50R 的建议值 (经 ISO DIS 6358-2 核准) 通过具备计算能力的测试台, 以符合 ISO 5167 标准孔板量规的过滤器进行了流量测试。

MRF G 1/4"

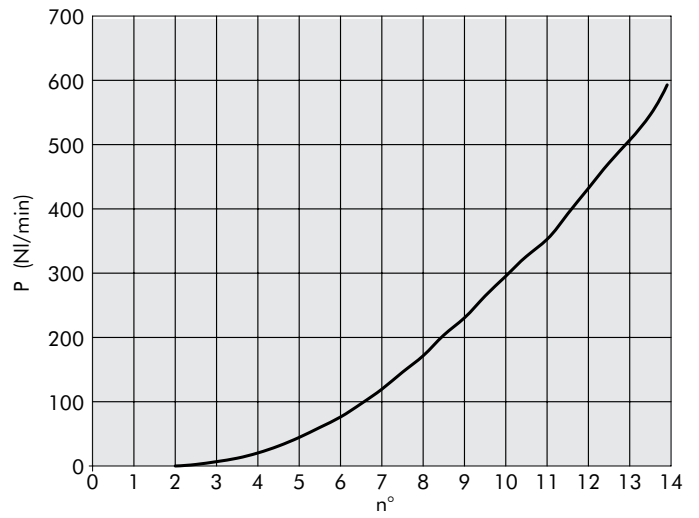

Ø10 管径的流量

MRF G 3/8"

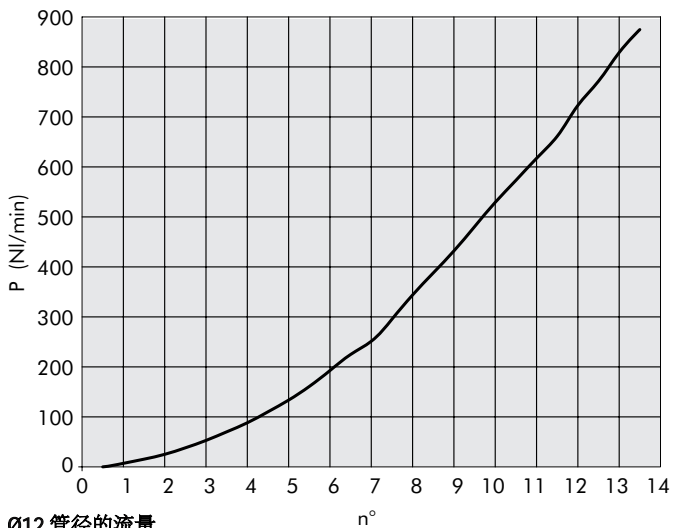

Ø12 管径的流量

MRF G 1/2"

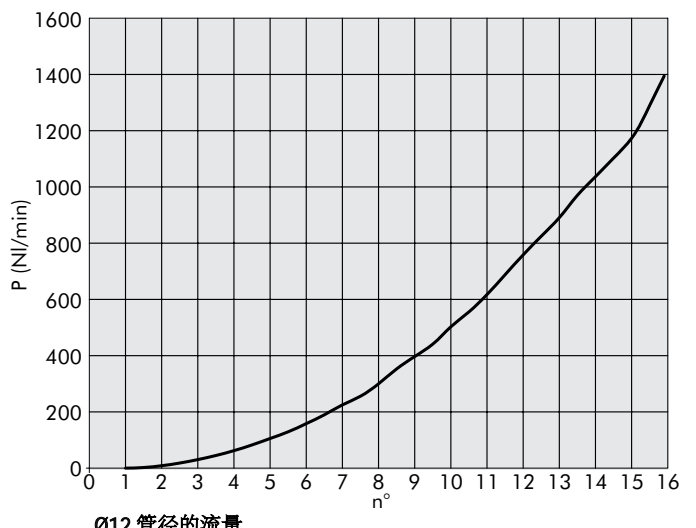

Ø12 管径的流量

尺寸：黄铜阀体（快插）

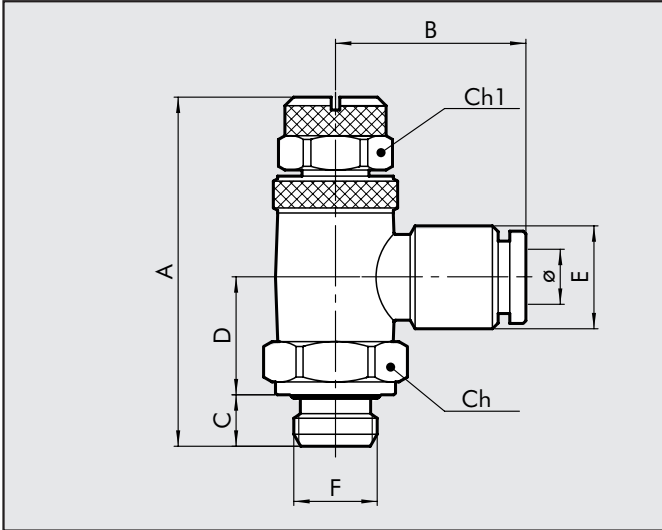

	F	∅	Ch	Ch1	E	B	A	D	C
	M5	4	9	9	10.9	23.5	28.2	9.3	4
	M5	5	9	9	12	24.5	28.2	9.3	4
	M5	6	9	9	13.5	24.5	28.2	9.3	4
	G 1/8	4	15	12	11.5	25	42	13.7	6
	G 1/8	5	15	12	12.0	25	42	13.7	6
	G 1/8	6	15	12	13.5	25	42	13.7	6
	G 1/8	8	15	12	15.5	30	42	13.7	6
	G 1/4	6	18	12	13.5	27.5	48	16	8
	G 1/4	8	18	12	15.5	32	48	16	8
	G 1/4	10	18	12	18	34.3	48	16	8
	G 1/4	12	18	12	20.2	37.5	48	16	8
	G 3/8	10	21	14	18	36.3	53	19	9
	G 3/8	12	21	14	20.2	40.5	53	19	9
	G 1/2	12	26	17	20.2	40.5	60.5	22	11

尺寸：高分子聚合材质阀体（快插）

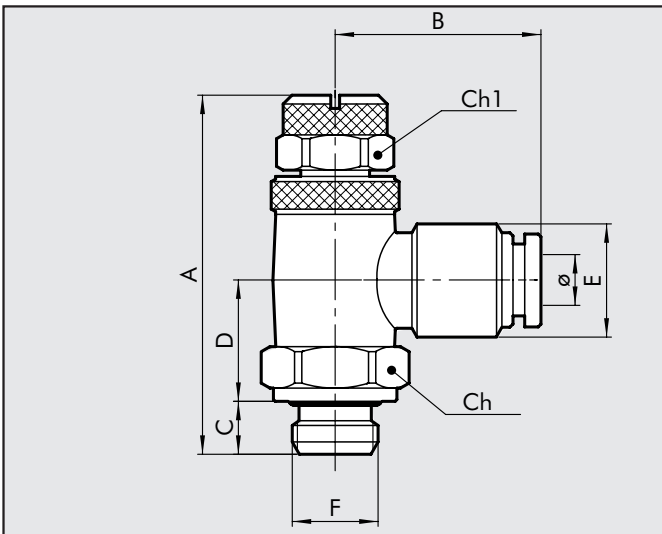

	F	∅	Ch	Ch1	E	B	A	D	C
	M5	4	9	9	10.9	20	28.2	9.3	4
	M5	5	9	9	13.5	21.5	28.2	9.3	4
	M5	6	9	9	15	22	28.2	9.3	4
	G 1/8	4	15	12	12.5	22.5	42	14.7	6
	G 1/8	5	15	12	13.5	23	42	14.7	6
	G 1/8	6	15	12	15	22.5	42	14.7	6
	G 1/8	8	15	12	16.3	25.5	42	14.7	6
	G 1/4	6	18	12	15	24	48	17	8
	G 1/4	8	18	12	16.3	27	48	17	8
	G 1/4	10	18	12	18.5	31	48	17	8
	G 1/4	12	18	12	21	32	48	17	8
	G 3/8	10	21	14	18.5	31	53	20	9
	G 3/8	12	21	14	21	33	53	20	9
	G 1/2	12	26	17	21	35	60.5	22	11

尺寸：阀体（带螺纹）

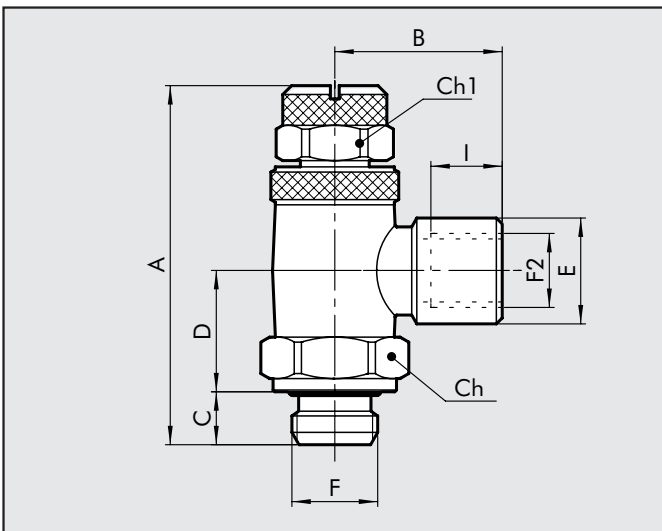

	F	F <sub>2</sub>	Ch	Ch1	E	B	A	D	C	I
	G 1/8	G 1/8	15	12	13.3	21.4	42	13.7	6	6.7
	G 1/4	G 1/4	18	12	16.7	25.5	48	16	8	8
	G 3/8	G 3/8	21	14	20.2	31.5	53	19	9	10



# 订货代号

## MRF/C 型黄铜阀体

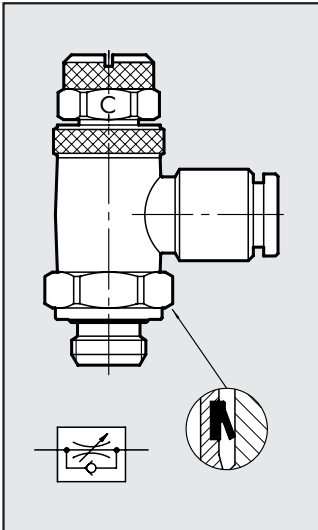

代号 参照

9031001	MRF/C 4 M5
9031002	MRF/C 4 1/8
9031003	MRF/C 5 M5
9031004	MRF/C 5 1/8
9031005	MRF/C 6 M5
9031006	MRF/C 6 1/8
9031007	MRF/C 6 1/4
9031008	MRF/C 8 1/8
9031009	MRF/C 8 1/4
9031011	MRF/C 10 1/4
9031012	MRF/C 10 3/8
9031014	MRF/C 12 1/4
9031015	MRF/C 12 3/8
9031016	MRF/C 12 1/2

## MRFT/C 型高分子聚合材质阀体

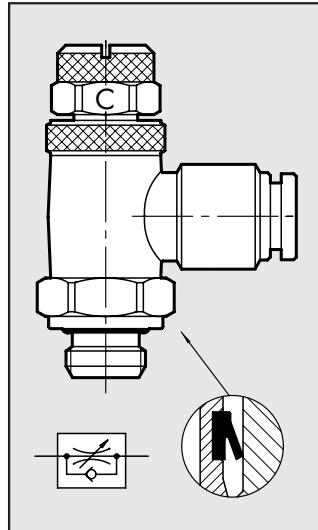

代号 参照

9021001	MRFT/C 4 M5
9021002	MRFT/C 4 1/8
9021003	MRFT/C 5 M5
9021004	MRFT/C 5 1/8
9021005	MRFT/C 6 M5
9021006	MRFT/C 6 1/8
9021007	MRFT/C 6 1/4
9021008	MRFT/C 8 1/8
9021009	MRFT/C 8 1/4
9021011	MRFT/C 10 1/4
9021012	MRFT/C 10 3/8
9021014	MRFT/C 12 1/4
9021015	MRFT/C 12 3/8
9021016	MRFT/C 12 1/2

## MRF/V 型黄铜阀体

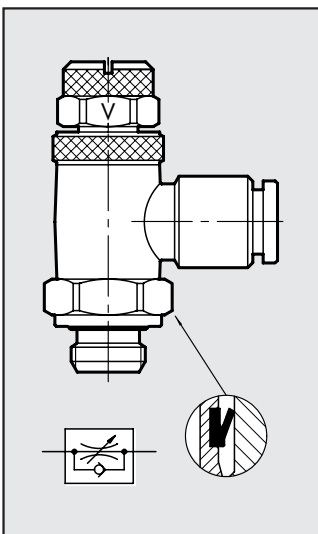

代号 参照

9031101	MRF/V 4 M5
9031102	MRF/V 4 1/8
9031103	MRF/V 5 M5
9031104	MRF/V 5 1/8
9031105	MRF/V 6 M5
9031106	MRF/V 6 1/8
9031107	MRF/V 6 1/4
9031108	MRF/V 8 1/8
9031109	MRF/V 8 1/4
9031111	MRF/V 10 1/4
9031112	MRF/V 10 3/8
9031114	MRF/V 12 1/4
9031115	MRF/V 12 3/8
9031116	MRF/V 12 1/2

## MRFT/V 型高分子聚合材质阀体

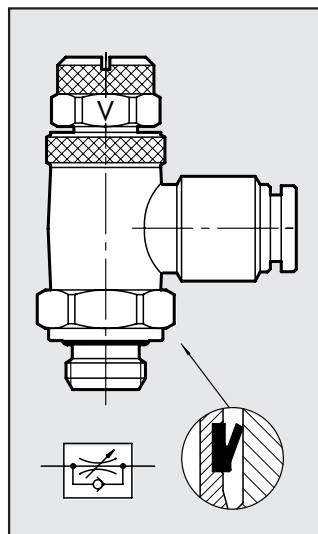

代号 参照

9021101	MRFT/V 4 M5
9021102	MRFT/V 4 1/8
9021103	MRFT/V 5 M5
9021104	MRFT/V 5 1/8
9021105	MRFT/V 6 M5
9021106	MRFT/V 6 1/8
9021107	MRFT/V 6 1/4
9021108	MRFT/V 8 1/8
9021109	MRFT/V 8 1/4
9021111	MRFT/V 10 1/4
9021112	MRFT/V 10 3/8
9021114	MRFT/V 12 1/4
9021115	MRFT/V 12 3/8
9021116	MRFT/V 12 1/2

## MRF/B 型黄铜阀体

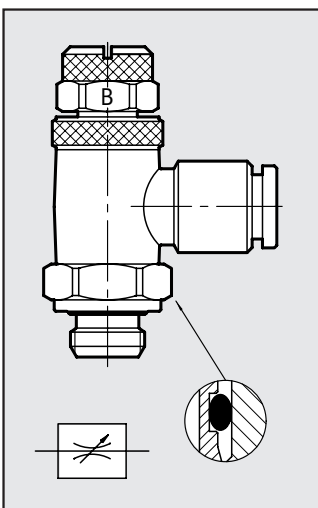

代号 参照

9031201	MRF/B 4 M5
9031202	MRF/B 4 1/8
9031203	MRF/B 5 M5
9031204	MRF/B 5 1/8
9031205	MRF/B 6 M5
9031206	MRF/B 6 1/8
9031207	MRF/B 6 1/4
9031208	MRF/B 8 1/8
9031209	MRF/B 8 1/4
9031211	MRF/B 10 1/4
9031212	MRF/B 10 3/8
9031214	MRF/B 12 1/4
9031215	MRF/B 12 3/8
9031216	MRF/B 12 1/2

## MRFT/B 型高分子聚合材质阀体

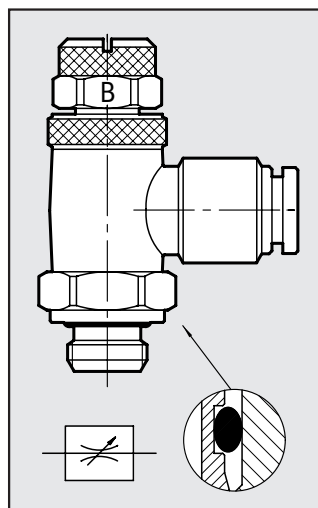

代号 参照

9021201	MRFT/B 4 M5
9021202	MRFT/B 4 1/8
9021203	MRFT/B 5 M5
9021204	MRFT/B 5 1/8
9021205	MRFT/B 6 M5
9021206	MRFT/B 6 1/8
9021207	MRFT/B 6 1/4
9021208	MRFT/B 8 1/8
9021209	MRFT/B 8 1/4
9021211	MRFT/B 10 1/4
9021212	MRFT/B 10 3/8
9021214	MRFT/B 12 1/4
9021215	MRFT/B 12 3/8
9021216	MRFT/B 12 1/2

**MRF/CF 型黄铜阀体**

代号      参照

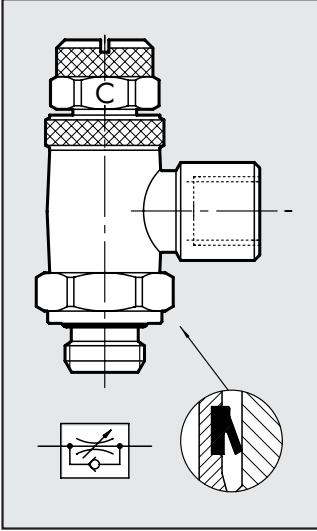

- 9031301      MRF/CF 1/8 1/8
- 9031302      MRF/CF 1/4 1/4
- 9031303      MRF/CF 3/8 3/8

**备注**

**MRF/VF 型黄铜阀体**

代号      参照

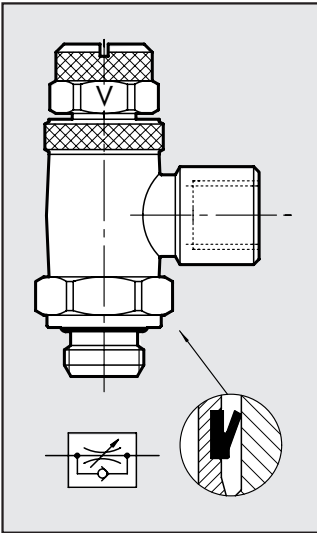

- 9031401      MRF/VF 1/8 1/8
- 9031402      MRF/VF 1/4 1/4
- 9031403      MRF/VF 3/8 3/8

**MRF/BF 型黄铜阀体**

代号      参照

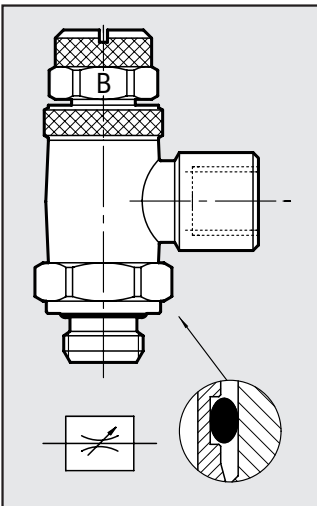

- 9031501      MRF/BF 1/8 1/8
- 9031502      MRF/BF 1/4 1/4
- 9031503      MRF/BF 3/8 3/8