

# COMPACT CYLINDERS SERIES "CMPC" Ø 32÷80 TWO-FLAT

This version is used to keep at an angle the objects fixed onto the piston rod and to apply torques within the specified limits.

The piston rod in two-flat cylinders has two opposing longitudinal surfaces and is made entirely of stainless steel. The front head of the cylinder includes a sintered bronze bush that engages the piston rod and prevents it from rotating.

A special polyurethane gasket guarantees air-tightness and dirt removal.

This technical solution is more airtight and reliable than square or hexagonal piston rods.

These compact cylinders come in the following versions:

- with or without a magnet
- dual-acting, single piston rod
- dual-acting, through piston rod – one piston rod is two-flat, and the other is cylindrical
- fixing centre distances compatible with ,ISO 15552 (former ISO 6431), or with French standard NFE 49-004-1 and 2 (UNITOP).

The special profile and the fact that the external heads are screwed onto the liner give an excellent guide. Numerous fixing options are available thanks to wide range of anchor points.

Retractable magnetic limit switches can be mounted in slots in the cylinder to measure the position.



TECHNICAL DATA		POLYURETHANE
Operating pressure		max 10 bar (max 1 Mpa - 145 psi)
Temperature range	°C	-10 ÷ +80 °C (non-magnetic cylinder)
	°C	-10 ÷ +70 °C (magnetic cylinder)
Fluid		Unlubricated air. Lubrication, if used, must be continuous.
Bores	mm	Ø 32, Ø 40, Ø 50, Ø 63, Ø 80 with ISO 6431 VDMA24562 fixing centre distances.
	mm	Ø 32, Ø 40, Ø 50, Ø 63, Ø 80 with NFE 49-004-1 and 2 fixing centre distances.
Design		With profile, heads with screws
Maximum strokes †	mm	ø32 e ø40 = 300    ø50 e ø63 = 400    ø80 = 500
Versions		Double-acting, Double-acting Through-rod,
Magnet for sensors		All versions come complete with magnet. Supplied without magnet on request.
Inrush pressure		ø32 = 0,8 bar    da ø40 a ø80 = 0,6 bar
Max torque on piston rod	Nm	ø32 e ø40 = 0,2;    ø50 e ø63 = 0,4;    ø80 = 1
Maximum rotation on the rod	degrees	ø32 e ø40 = 0,70°;    ø50 e ø63 = 0,75°;    ø80 = 0,65°
		† Maximum recommended strokes. Higher values can create operating problems
		For no-stick slip versions, are no-lubricated air only

## WEIGHT

Ø	SINGLE-ROD	
	Weight [g] Stroke=0	Weight [g] each mm
32	261	3.17
40	394	4.41
50	595	6.42
63	845	7.34
80	1524	12.57

Ø	THROUGH-ROD	
	Weight [g] Stroke=0	Weight [g] each mm
32	297	4.05
40	432	5.29
50	648	7.98
63	129	8.90
80	1680	15.02



## FORCES GENERATED DURING THRUST AND TRACTION (THEORETICAL)

Cylinder bore D mm	Piston rod diameter d mm	Motion	Useful area cm <sup>2</sup>	Thrust and traction force in daN depending on the operating pressure in bar.									
				1 bar	2 bar	3 bar	4 bar	5 bar	6 bar	7 bar	8 bar	9 bar	10 bar
32	12	spinta	8.04	8.0	16.1	24.1	32.2	40.2	48.3	56.3	64.3	72.4	80.4
		trazione	6.91	6.9	13.8	20.7	27.6	34.6	41.5	48.4	55.3	62.2	69.1
40	12	spinta	12.57	12.6	25.1	37.7	50.3	62.8	75.4	88.0	100.5	113.1	125.7
		trazione	11.44	11.4	22.9	34.3	45.7	57.2	68.6	80.0	91.5	102.9	114.4
40	16	spinta	12.57	12.6	25.1	37.7	50.3	62.8	75.4	88.0	100.5	113.1	125.7
		trazione	10.56	10.6	21.1	31.7	42.2	52.8	63.3	73.9	84.4	95.0	105.6
50	16	spinta	19.63	19.6	39.3	58.9	78.5	98.2	117.8	137.4	157.1	176.7	196.3
		trazione	17.62	17.6	35.2	52.9	70.5	88.1	105.7	123.4	141.0	158.6	176.2
50	20	spinta	19.63	19.6	39.3	58.9	78.5	98.2	117.8	137.4	157.1	176.7	196.3
		trazione	16.49	16.5	33.0	49.5	66.0	82.5	99.0	115.5	131.9	148.4	164.9
63	16	spinta	31.17	31.2	62.3	93.5	124.7	155.9	187.0	218.2	249.4	280.6	311.7
		trazione	29.16	29.2	58.3	87.5	116.6	145.8	175.0	204.1	233.3	262.5	291.6
63	20	spinta	31.17	31.2	62.3	93.5	124.7	155.9	187.0	218.2	249.4	280.6	311.7
		trazione	28.03	28.0	56.1	84.1	112.1	140.2	168.2	196.2	224.2	252.3	280.3
80	20	spinta	50.27	50.3	100.5	150.8	201.1	251.3	301.6	351.9	402.1	452.4	502.7
		trazione	47.12	47.1	94.2	141.4	188.5	235.6	282.7	329.9	377.0	424.1	471.2
80	25	spinta	50.27	50.3	100.5	150.8	201.1	251.3	301.6	351.9	402.1	452.4	502.7
		trazione	45.36	45.4	90.7	136.1	181.4	226.8	272.1	317.5	362.9	408.2	453.6

## COMPONENTS

- ① PISTON ROD: C45 steel or stainless steel, two-flat
- ② HEAD: extruded anodised aluminium alloy
- ③ JACKET: drawn anodised and calibrated aluminium alloy
- ④ PISTON GASKET: polyurethane
- ⑤ MAGNET: Ø 32 neodymium - Ø 40÷100 plastoferrite
- ⑥ PISTON ROD GASKET TWO-FLAT: polyurethane
- ⑦ GUIDE BUSHING: steel strip with bronze
- ⑧ STATIC O-rings: NBR
- ⑨ SECURING SCREWS: zinc-plated steel

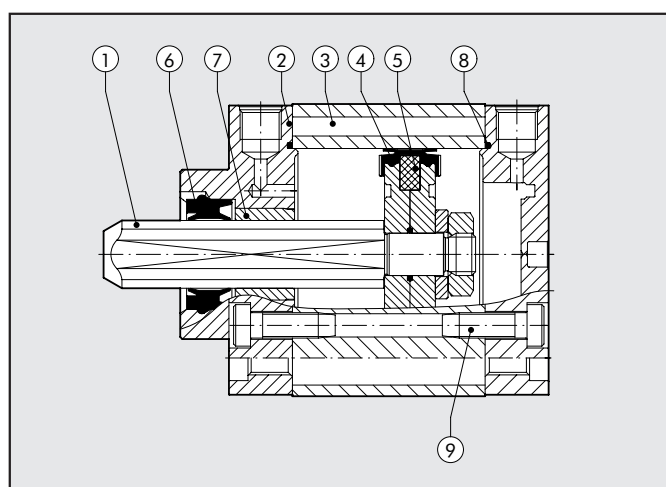

## TECHNICAL DATA

- ① Compact cylinder available with two separate fixing centre distances
  - Ø 32÷ 80 to ISO 15552 ( former ISO 6431)
  - Ø 32÷ 80 to NFE 49-004-1 and 2
- ② Pre-wired retracting sensor with or without connector
- ③ Plastic strip to keep out dirt and/or protect the sensor wire cod. W0950000160
- ④ Ball-and-socket joint code W095... 2030
- ⑤ Example of cylinder mounting with feet code W095... 6001
- ⑥ Sensor slot
- ⑦ Piston rod with male or female thread as required

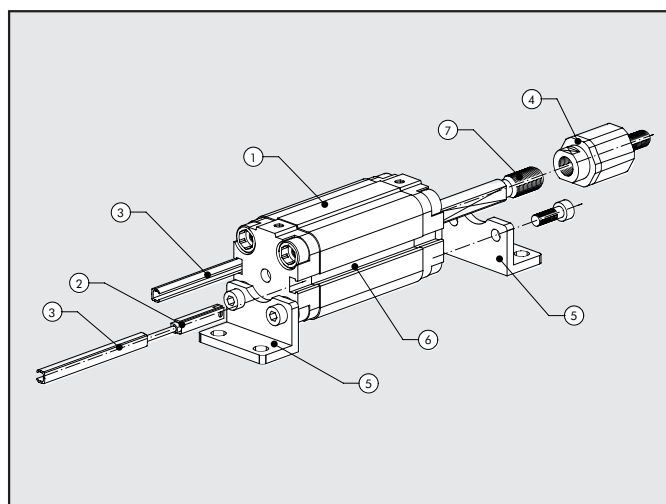

## FIXING OPTIONS

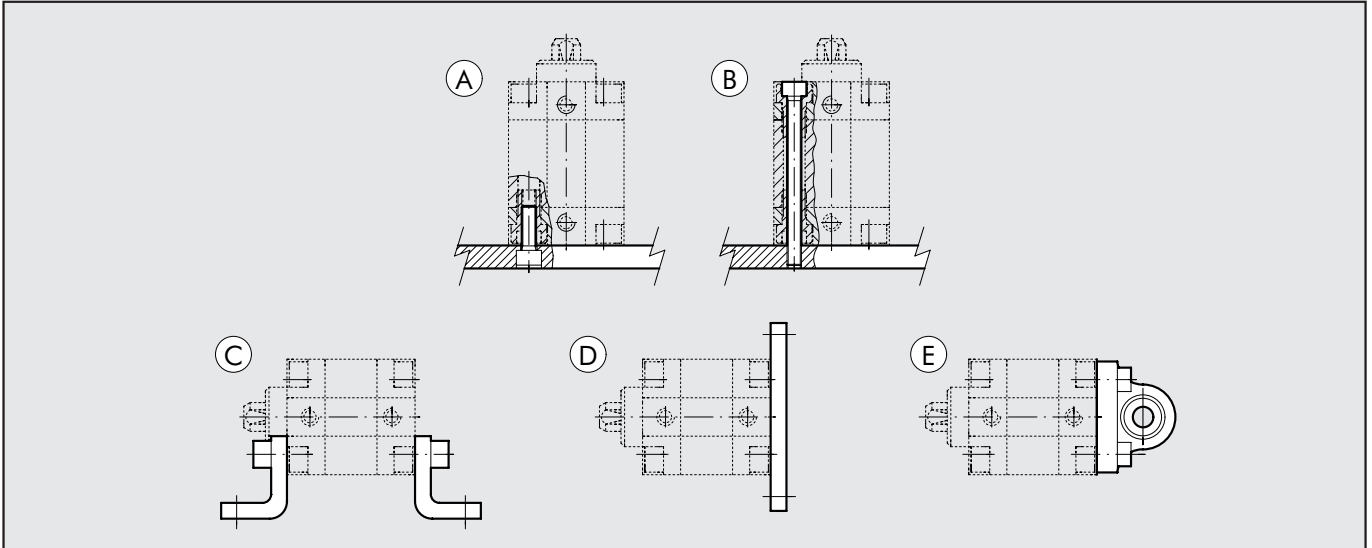

- A** - Fixing to structural work with a through screw, using the thread in the heads (Fig. A)
- B** - Direct fixing from above using long through screws or tie rods. Non-magnetic stainless steel must be used (e.g. AISI 304)
- C** - Fixing with feet; the ordering code covers the supply of one foot and two screws for fixing to the cylinder.
- D** - Fixing with a flange mounted on the front or rear head; the ordering code covers the supply of a flange and four screws for fixing to the cylinder.
- E** - Fixing with articulated hinge to compensate for slight system misalignment and turn freely. The ordering code covers the supply of a hinge and four screws for fixing to the cylinder.

## VALVE ASSEMBLY ON CYLINDER

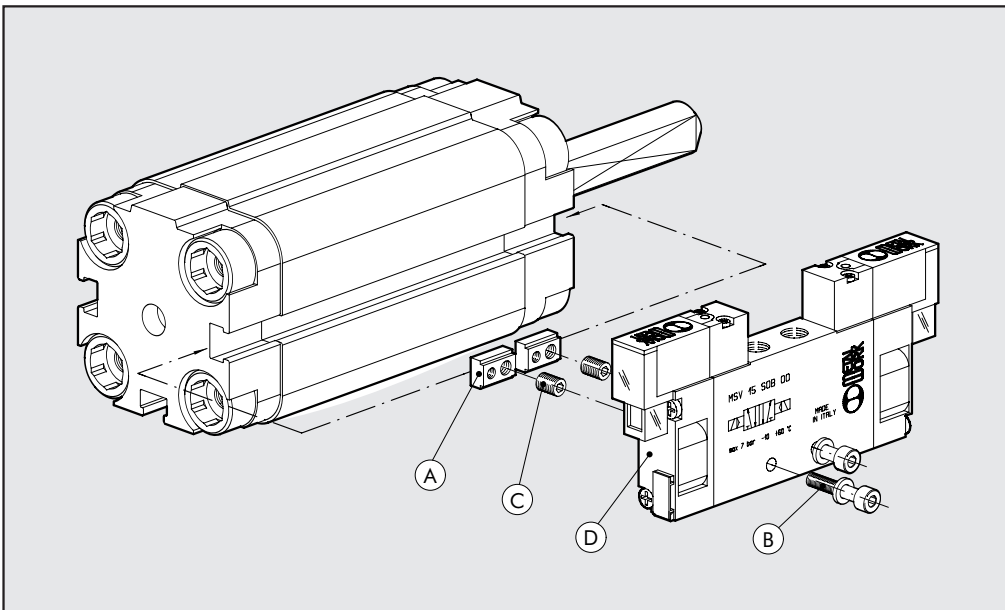

With this type of cylinder, the valves (D) can be mounted directly using the retracting sensor slot, without requiring the use of intermediate brackets. This can be done using the special plates (A) which come with both M3 and M4 threads, and screws (B) of the size, type and quantity shown in the table below.

The plates are supplied complete with 2 stud pins, one M3 and one M4 (C).

After the valve centre distance and the position of the valve have been determined, the plates can be secured to the cylinder. A "position memory" will be created to facilitate subsequent maintenance on the valve.

Type of valve to mount (D)	Fixing plate (A) cod. 0950003000	Position memory: grub screw (C) to be used	Screw (B) for connection to the cylinder (one per plate)	Washer (B) (one per screw)
MACH 11	n. 2	M4	M3x16 UNI 5931 (DIN 912)	A3.2 UNI 1751 (DIN 127A)
SERIE 70 1/8	n. 2	M3	M4x25 UNI 5931 (DIN 912)	—
SERIE 70 1/4	n. 2	M3	M4x30 UNI 5931 (DIN 912)	A4.3 UNI 1751 (DIN 127A)

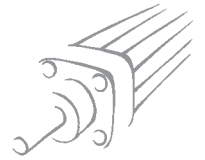

**DIMENSIONS OF DOUBLE-ACTING**

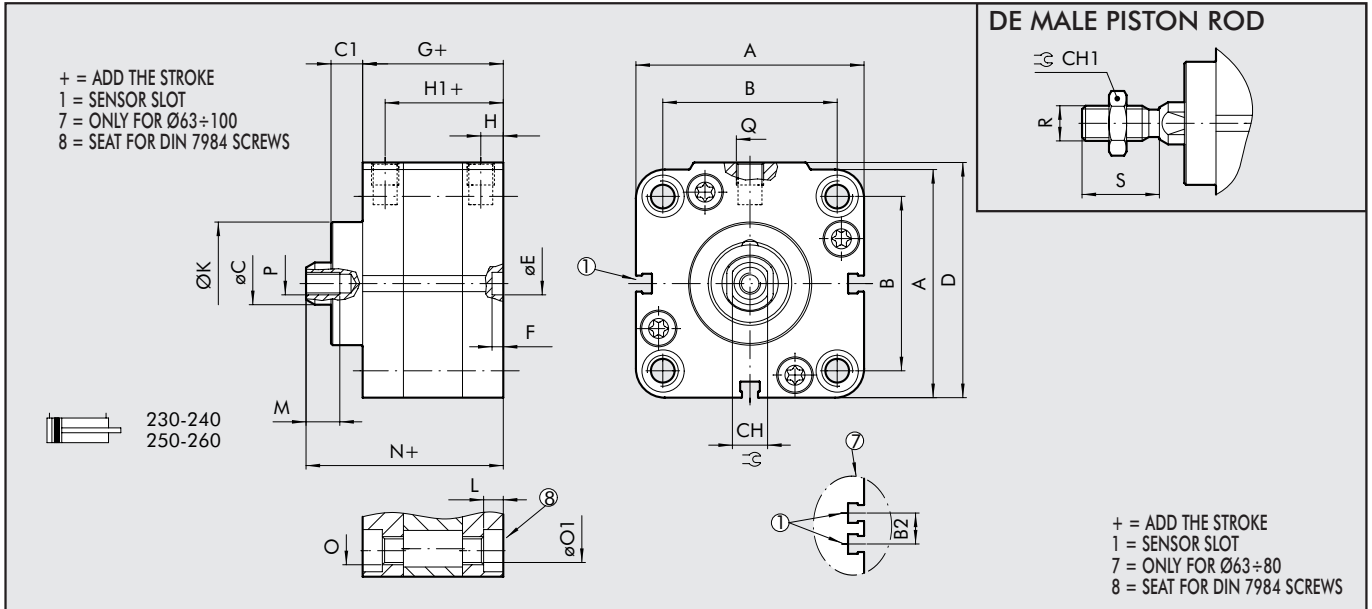

	B		B2	ØC	C1	CH	CH1	D	ØE	H9	F	G	H	H1	ØK	L	M	N	O		ØO1		P	Q	R	S
	A	ISO																	UNITOP	ISO	UNITOP					
Ø 32	47	32.5 <sup>+0.1</sup> <sub>-0.4</sub>	32 <sup>+0.4</sup> <sub>-0.1</sub>	-	12	9	10	17	48.5	6	4	44.5	7.5	37	30	4	14	59.5	M6	M6	5.2	5.2	M6	G1/8	M10x1.25	22
Ø 40	56	38	42	-	12	9	10	17	57.5	6	4	45.5	7.5	38	35	4.5	14	61	M6	M6	5.2	5.2	M6	G1/8	M10x1.25	22
Ø 50	67	46.5	50	-	16	11.5	13	19	69	6	4	45.5	7.5	38	40	4.5	16	64.5	M8	M8	6.2	6.2	M8	G1/8	M12x1.25	24
Ø 63	80	56.5	62	13	16	11.5	13	19	82	8	4	50	7.5	42.5	45	5.5	16	69	M8	M10	6.2	8.5	M8	G1/8	M12x1.25	24
Ø 80	102	72	82	17	20	13	17	24	105	8	4	56	8.5	47.5	45	5.5	20	77	M10	M10	8.5	8.5	M10	G1/8	M16x1.5	32

**DIMENSIONS OF THROUGH-ROD**

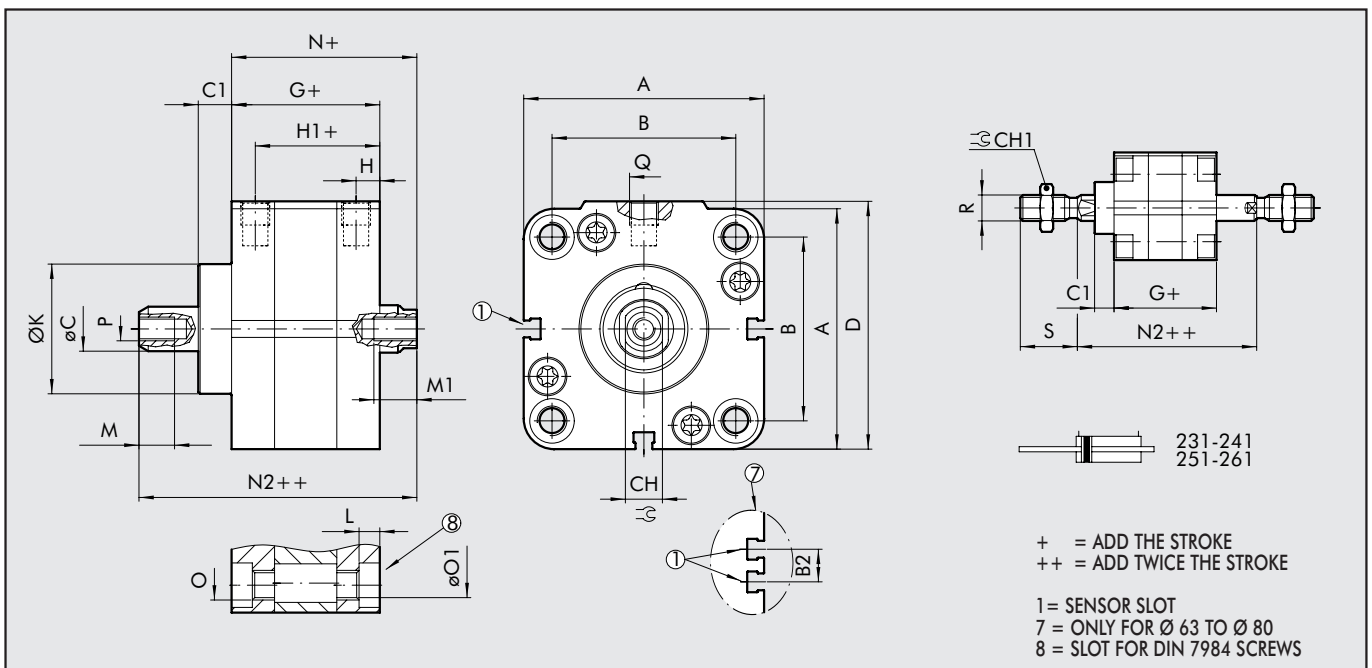

	B		B2	ØC	C1	CH	CH1	D	G	H	H1	ØK	L	M	M1xcourse		N	N2	O		ØO1		P	Q	R	S
	A	ISO													UNITOP	ISO			UNITOP	≥ 5	< 5	ISO				
Ø 32	47	32.5 <sup>+0.1</sup> <sub>-0.4</sub>	32 <sup>+0.4</sup> <sub>-0.1</sub>	-	12	9	10	17	48.5	44.5	7.5	37	30	4	14	9	50.5	65.5	M6	M6	5.2	5.2	M6	G1/8	M10x1.25	22
Ø 40	56	38	42	-	12	9	10	17	57.5	45.5	7.5	38	35	4.5	14	9	52	67.5	M6	M6	5.2	5.2	M6	G1/8	M10x1.25	22
Ø 50	67	46.5	50	-	16	11.5	13	19	69	45.5	7.5	38	40	4.5	16	11	53	72	M8	M8	6.2	6.2	M8	G1/8	M12x1.25	24
Ø 63	80	56.5	62	13	16	11.5	13	19	82	50	7.5	42	45	5.5	16	11	57.5	76.5	M8	M10	6.2	8.5	M8	G1/8	M12x1.25	24
Ø 80	102	72	82	17	20	13	17	24	105	56	8.5	47.5	45	5.5	20	15	64	85	M10	M10	8.5	8.5	M10	G1/8	M16x1.5	32

### KEY TO CODE

CIL	2	3	1	0	3 2	0	0 5 0	F	P
	TYPE		BORE			STROKE *		CONFIGURATION	
23	Compact cylinder centre distances to UNITOP male piston rod	0 Double-acting 1 Double-acting through-rod	0 Magnetic S Non- magnetic G No stick slip	32 40 50 63 80	0 Standard			F "Two Flat" piston rod AISI 303 stainless stell	P Polyurethane gaskets
24	Compact cylinder centre distances to UNITOP female piston rod								
25	Compact cylinder centre distances to ISO male piston rod								
26	Compact cylinder centre distances to ISO female piston rod								

\* For the maximum suppliable strokes, look at the technical data

## ACCESSORIES

### FOOT - MODEL A

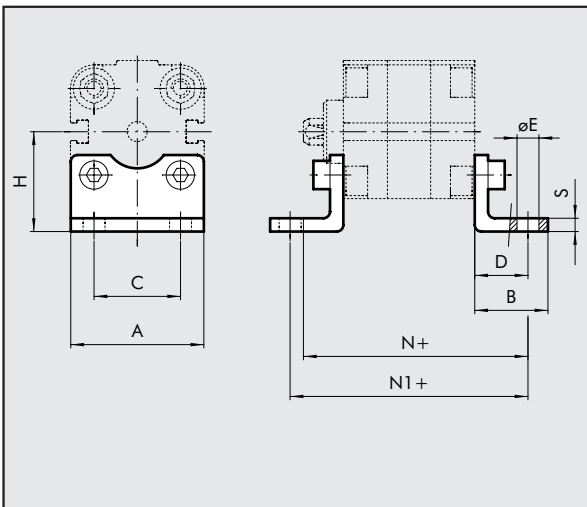

Codes UNITOP	Ø	A	B	C	D	ØE	H	N	N1	S	Weight [g]
W0950322001	32	45	35	32	24	7	s31.9	74.5	92.5	4	76
W0950406001F	40	60	28	42	20	9	42.5	72	85.5	5	88
W0950506001F	50	68	32	50	24	9	47	77	93.5	6	176
W0950636001F	63	84	39	62	27	11	59.5	84.5	104	6	276
W0950806001	80	102	42	82	30	11	65.5	94	116	8	392

Codes ISO	Ø	A	B	C	D	ØE	H	N	N1	S	Weight [g]
W0950322001	32	45	35	32	24	7	31.9	74.5	92.5	4	76
W0950402001	40	52	43	36	28	9	36	80	101.5	4	100
W0950502001	50	65	47	45	32	9	45	85	109.5	4	162
W0950632001	63	75	47	50	32	9	50	89.5	114	6	266
W0950802001	80	95	61	63	41	12	63	105	138	6	456

Note: Individually packed with 2 screws.

### FEMALE HINGE-MODEL B

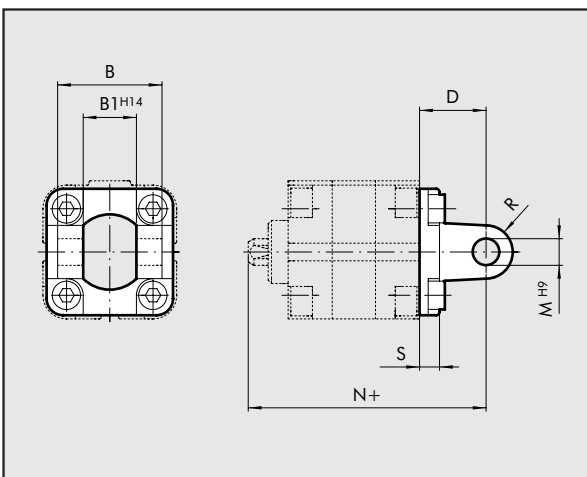

Codes UNITOP	Ø	B	B1	D	M	N	R	S	Weight [g]
W0950322003	32	45	26	22	10	72.5	11	10	116
W0950406003	40	52	28	25	12	77	12.5	9	184
W0950506003	50	60	32	27	12	80	12.5	11	266
W0950636003	63	70	40	32	16	89.5	15	11	470
W0950806003	80	90	50	36	16	100	15	13	670

  

Codes ISO	Ø	B	B1	D	M	N	R	S	Weight [g]
W0950322003	32	45	26	22	10	72.5	11	10	116
W0950402003	40	52	28	25	12	77	13	10	160
W0950502003	50	60	32	27	12	80	13	12	252
W0950632003	63	70	40	32	16	89.5	17	12	394
W0950802003	80	90	50	36	16	100	17	16	670

Note: Supplied with 4 screws, 4 washers, 2 snap-rings and 1 pin.



**MALE HINGE-MODEL BA**

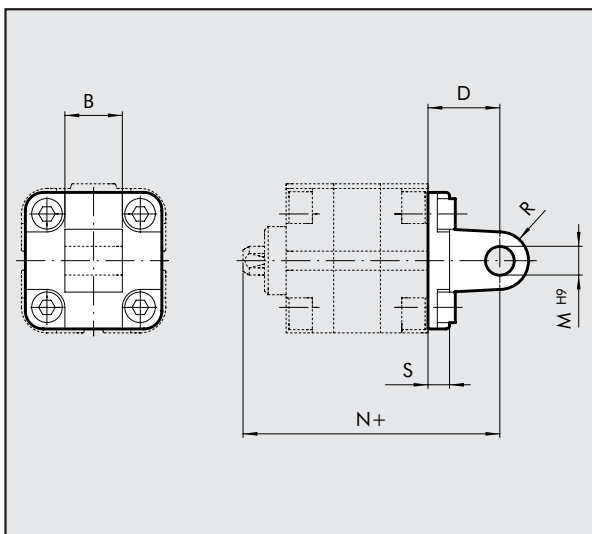

Codes ISO	Ø	B	D	M	N	R	S	Weight [g]
W0950322004	32	26	22	10	72.5	11	10	94
W0950402004	40	28	25	12	77	13	10	124
W0950502004	50	32	27	12	80	13	12	220
W0950632004	63	40	32	16	89.5	17	12	316
W0950802004	80	50	36	16	100	17	16	578

Note: Supplied with 4 screws, 4 washers

**FLANGE - MODEL C (FRONT AND REAR)**

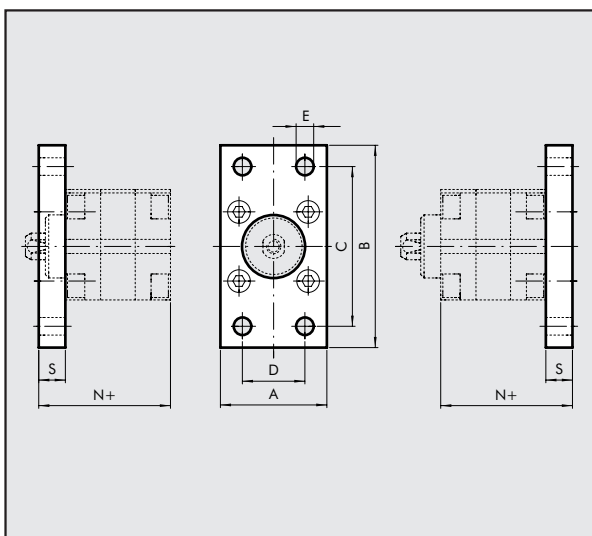

Codes UNITOP	Ø	A	B	C	D	E	N	S	Weight [g]
W0950322002	32	50	80	64	32	7	54.5	10	246
W0950406002F	40	60	102	82	36	9	55.5	10	454
W0950506002F	50	68	110	90	45	9	57.5	12	655
W0950636002F	63	87	130	110	50	9	65	15	1255
W0950806002F	80	107	160	135	63	12	71	15	1900

Codes ISO	Ø	A	B	C	D	E	N	S	Weight [g]
W0950322002	32	50	80	64	32	7	54.5	10	246
W0950402002	40	55	90	72	36	9	55.5	10	290
W0950502002	50	65	110	90	45	9	57.5	12	522
W0950632002	63	75	120	100	50	9	62	12	670
W0950802002	80	95	153	126	63	12	72	16	1420

Note: Supplied with 4 screws.

**ARTICULATED MALE HINGE - MODEL BAS**

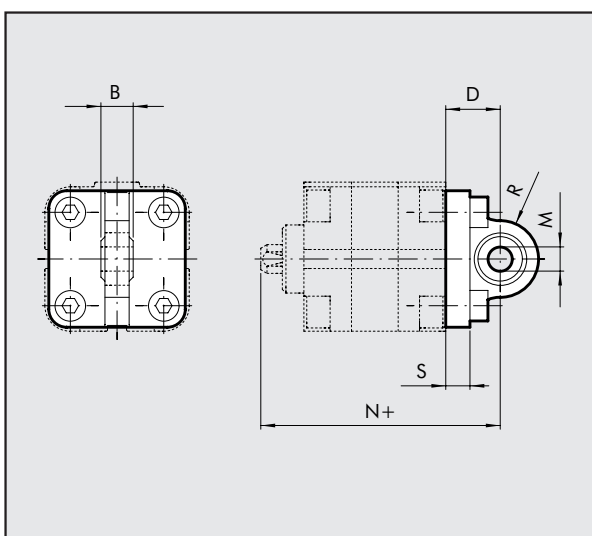

Codes ISO	Ø	B	D	M	N	R	S	Weight [g]
W0950322006	32	14	22	10	72.5	16	10	106
W0950402006	40	16	25	12	77	19	10	142
W0950502006	50	16	27	12	80	19	12	236
W0950632006	63	21	32	16	89.5	24	12	336
W0950802006	80	21	36	16	100	24	16	572

Note: Supplied with 4 screws, 4 washers.

### FLANGE FOR OPPOSITE CYLINDERS

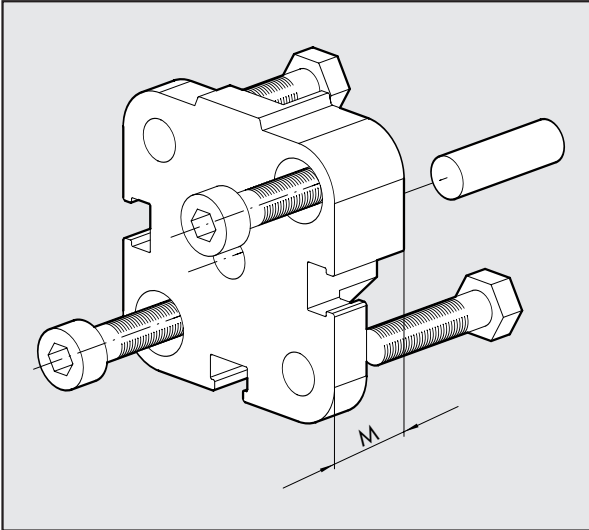

Codes UNITOP	Codes ISO	Ø	M	Weight [g]	
				UNITOP	ISO
0950323060	0950323060	32	14.5	88	88
0950403060	0950403061	40	14.5	106	106
0950503060	0950503061	50	14.5	172	158
0950633060	0950633061	63	14.5	274	258
0950803060	0950803061	80	16.5	470	452

Note: Supplied complete with 1 pin, 4 screws.

### ASSEMBLING OPPOSING CYLINDERS

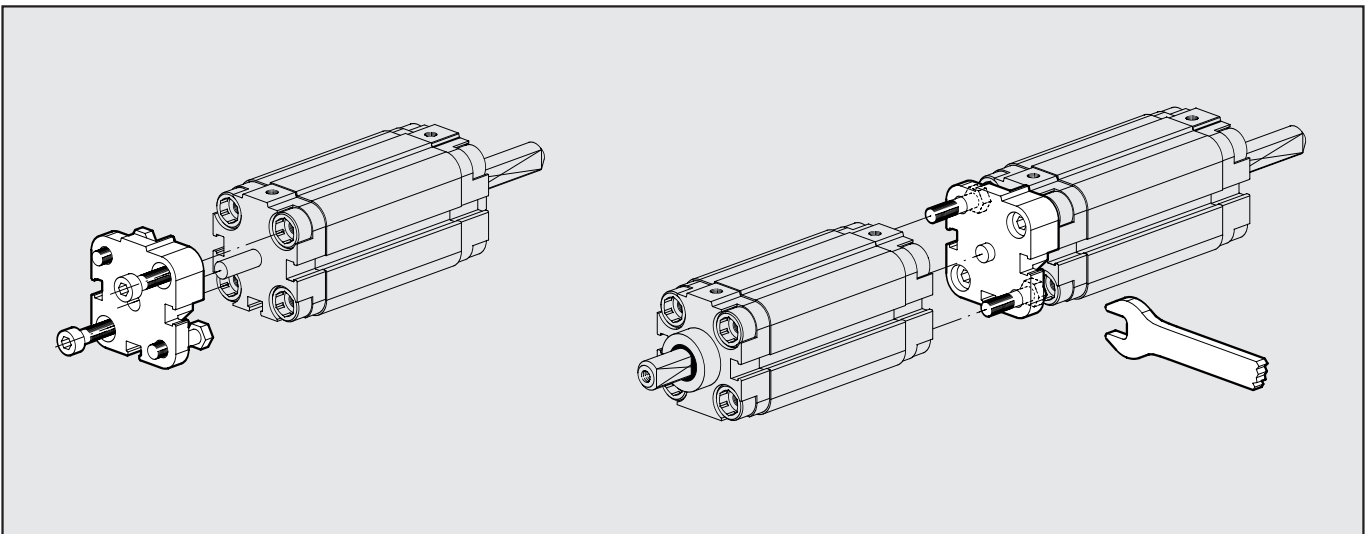

### FORK - MODEL GK-M

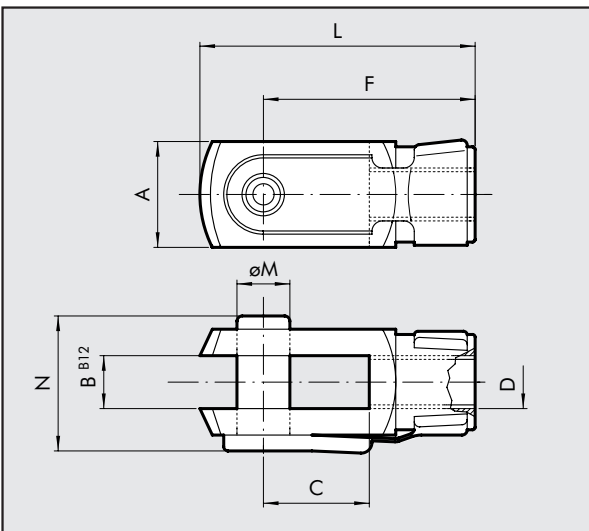

Codes UNITOP-ISO	Ø	A	B	C	D	F	L	ØM	N	Weight [g]
W0950322020	32	20	10	20	M10x1.25	40	52	10	26	92
W0950322020	40	20	10	20	M10x1.25	40	52	10	26	92
W0950402020	50	24	12	24	M12x1.25	48	62	12	32	148
W0950402020	63	24	12	24	M12x1.25	48	62	12	32	148
W0950502020	80	32	16	32	M16x1.5	64	83	16	40	340

Note: Individually packed.



**ROD EYE - MODEL GA-M**

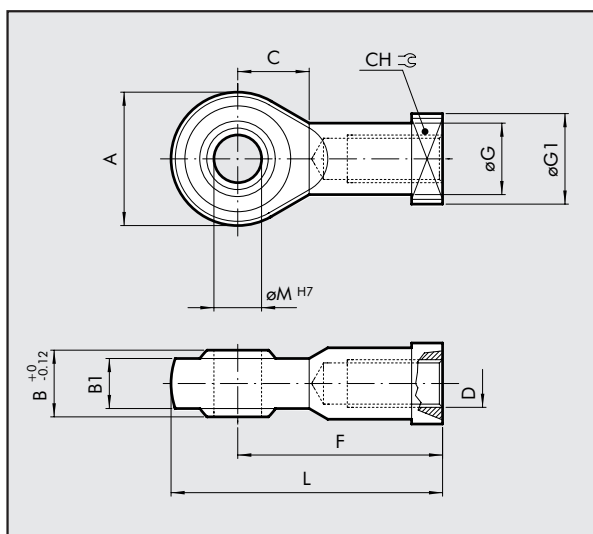

Codes	UNITOP-ISO	Ø	A	B	B1	C	CH	D	F	ØG	ØG1	L	ØM	Weight [g]
W095032	2025	32	28	14	10.5	15	17	M10x1.25	43	15	19	57	10	78
W095032	2025	40	28	14	10.5	15	17	M10x1.25	43	15	19	57	10	78
W095040	2025	50	32	16	12	17	19	M12x1.25	50	17.5	22	66	12	116
W095040	2025	63	32	16	12	17	19	M12x1.25	50	17.5	22	66	12	116
W095050	2025	80	42	21	15	23	22	M16x1.5	64	22	27	85	16	226

Note: Individually packed.

**COMPENSATION JOINT - MODEL GA**

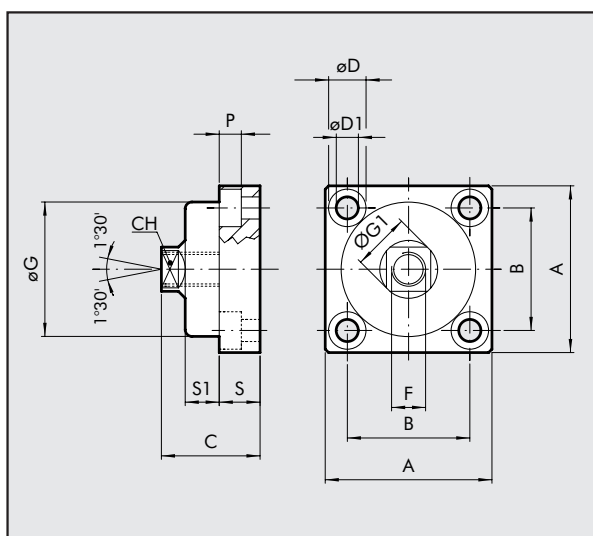

Codes	UNITOP-ISO	Ø	A	B	C	CH	ØD	ØD1	F	ØG	ØG1	P	S	S1
W095032	6021	32	49	36	30	13	11	6.5	M10x1.25	39.5	17	6.5	12	10
W095032	6021	40	49	36	30	13	11	6.5	M10x1.25	39.5	17	6.5	12	10
W095040	6021	50	59	42	36	15	14	8.5	M12x1.25	44	19	8.5	15	13.5
W095040	6021	63	59	42	36	15	14	8.5	M12x1.25	44	19	8.5	15	13.5
W095050	6021	80	79	58	44	22	17	10.5	M16x1.5	59	26	10.5	20	15

Note: Individually packed.

**COUNTER-HINGE CETOP**

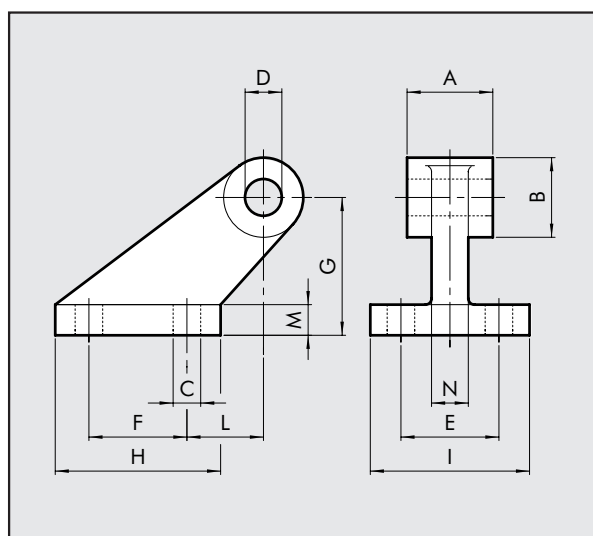

Codes	UNITOP-ISO	Ø	A	B	C	D	E	F	G	H	I	L	M	N	Weight [g]
W095032	2008	32	26	19	7	10	25	20	32	37	41	18	8	10	96
W095040	2008	40	28	26	9	12	32	32	45	54	52	25	10	12	216
W095050	2008	50	32	26	9	12	32	32	45	54	52	25	10	12	212
W095063	2008	63	40	33	11	16	40	50	63	75	63	32	12	15	440
W095080	2008	80	50	33	11	16	40	50	63	75	63	32	12	15	464

Note: Supplied complete with 4 screws, 4 washers.

### SELF ALIGNING ROD COUPLER - MODEL GA-K

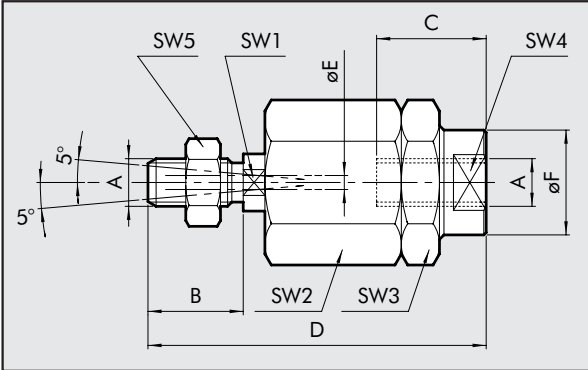

Codes UNITOP-ISO	Ø	A	B	C	D	ØE	ØF	SW1	SW2	SW3	SW4	SW5	Weight [g]
W0950322030	32	M10x1.25	20	20	71	4	22	12	30	30	19	17	216
W0950322030	40	M10x1.25	20	20	71	4	22	12	30	30	19	17	216
W0950402030	50	M12x1.25	24	20	75	4	22	12	30	30	19	19	220
W0950402030	63	M12x1.25	24	20	75	4	22	12	30	30	19	19	220
W0950502030	80	M16x1.5	32	32	103	4	32	20	41	41	30	24	620

Note: Individually packed.

### SLOTTED FIXINGPLATE

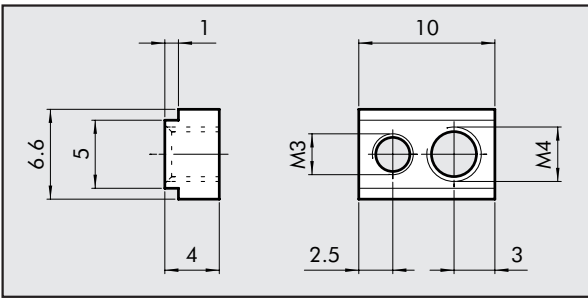

Code	Description	Weight [g]
0950003000	FIXING BLOCK	2

Note: Supplied complete with 1 M3 grub screw and 1 M4 grub screw.

### RETRACTABLE SENSOR WITH INSERTION FROM ABOVE

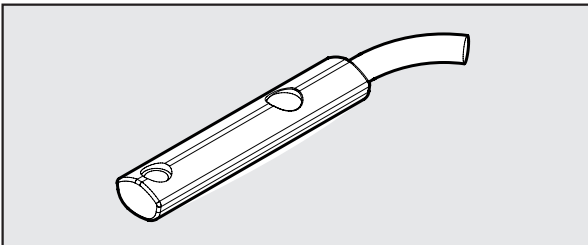

Code	Description
W0952025390	HALL N.O. SENSOR, VERTICAL INSERTION 2.5m
W0952029394	HALL N.O. SENSOR, VERTICAL INSERTION 300 mm M8
W0952022180	REED N.O. SENSOR, VERTICAL INSERTION 2.5m
W0952028184	REED N.O. SENSOR, VERTICAL INSERTION 300 mm M8
W0952125556	SENSORE HALL INS. VERT. NO 2 m ATEX

This type of sensor can be inserted in the slot of the sensor from above. This means the cylinder heads do not require a through opening.

### WIRING DIAGRAM

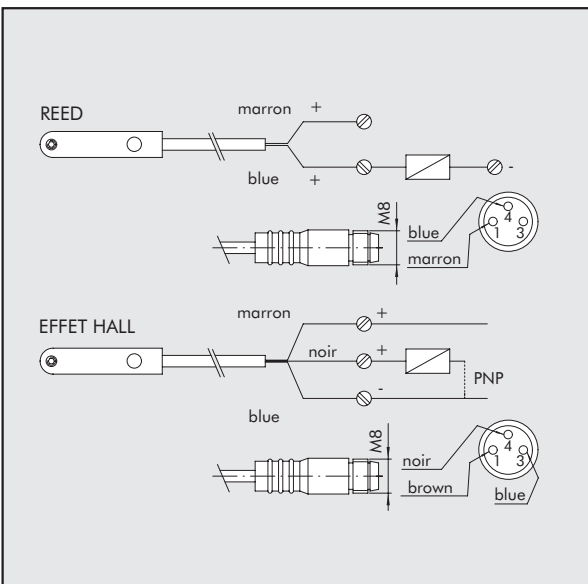

### TECHNICAL DATA

	Reed	Hall Effect
Type of contact	N.O.	N.O.
Switch	-	PNP
Supply voltage (U <sub>b</sub> )	V 10 ÷ 30 AC/DC	10 ÷ 30 DC
Power	W 3 (peak valve=6)	3
Voltage variation	-	≤ 10% di U <sub>b</sub>
Voltage drop	V -	≤ 2
Input current	mA -	≤ 10
Output current	mA ≤ 100	≤ 100
Switching frequency	Hz ≤ 400	≤ 5
Short-circuit protection	-	Yes
Over-voltage suppression	-	Yes
Polarity inversion protection	-	Yes
EMC	EN 60 947-5-2	EN 60 947-5-2
LED display	Yellow	Yellow
Magnetic sensitivity	2,8 mT ±25%	2,8 mT ±25%
Repeatability	≤ 0,1 mT	≤ 0,1 mT
Degree of protection (EN 60529)	IP 67	IP 67
Vibration and shock resistance	30 g, 11 ms, 10÷55 Hz, 1mm	30 g, 11 ms, 10÷55 Hz, 1mm
Temperature range	°C -25 ÷ +75	-25 ÷ +75
Sensor capsule material	PA66 + PA6I/6T	PA66 + PA6I/6T
2.5m connecting cable	PVC; 2 x 0,12 mm <sup>2</sup>	PVC; 3 x 0,14 mm <sup>2</sup>
Connecting cable with M8x1	Polyurethane; 2 x 0,14 mm <sup>2</sup>	Polyurethane; 3 x 0,14 mm <sup>2</sup>

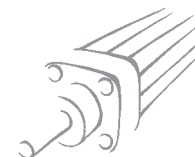

## BAR FOR GROOVING

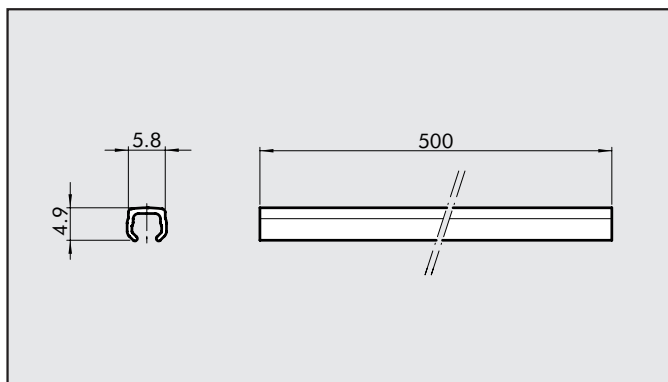

Code	Description
W0950000160	BAR FOR GROOVING L=500 mm

Note: The code corresponds to 1 piece.

## SPARE PARTS

### COMPACT CYLINDERS, SERIES "CMPC" TWO-FLAT

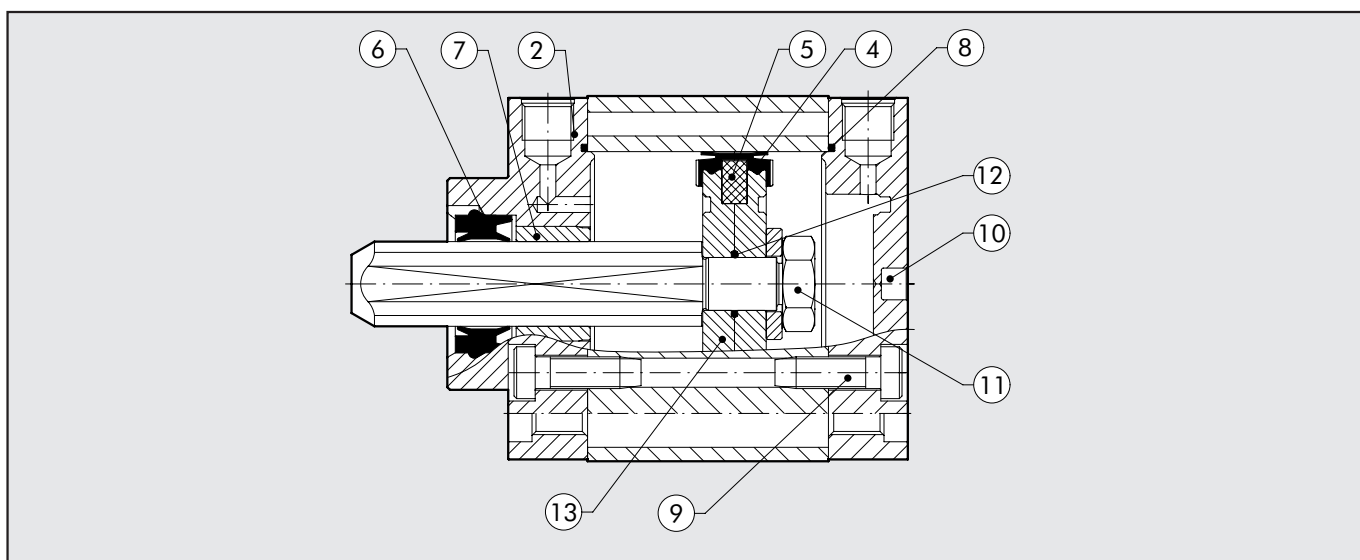

Type	Parts	Bores	Codes
Complete set of gaskets	④ ⑥ ⑧ ⑫	∅ 32÷80	009 ... 7001F
Front cylinder head kit for UNITOP	② ⑦ ⑥ ⑧ ⑨	∅ 40÷80	009 ... 7101F
Front cylinder head kit for ISO ∅ 32	② ⑦ ⑥ ⑧ ⑨	∅ 32	0090327101F
Front cylinder head kit for ISO	② ⑦ ⑥ ⑧ ⑨	∅ 40÷80	009 ... 8101F
Rear cylinder head kit for UNITOP	⑧ ⑨ ⑩	∅ 40÷80	009 ... 7201
Rear cylinder head kit for ISO ∅ 32	⑧ ⑨ ⑩	∅ 32	0090327201
Rear cylinder head kit for ISO	⑧ ⑨ ⑩	∅ 40÷80	009 ... 8201
Piston kit	④ ⑤ ⑪ ⑫ ⑬	∅ 32÷80	009 ... 7401
Magnet	⑤	∅ 32÷80	009 ... 7501
Front + rear cylinder head + piston kit for UNITOP	② ④ ⑤ ⑥ ⑦ ⑧ ⑨ ⑩ ⑪ ⑫ ⑬	∅ 40÷80	009 ... 7901F
Front + rear cylinder head + piston kit for ISO ∅ 32	② ④ ⑤ ⑥ ⑦ ⑧ ⑨ ⑩ ⑪ ⑫ ⑬	∅ 32	0090327901F
Front + rear cylinder head + piston kit for ISO	② ④ ⑤ ⑥ ⑦ ⑧ ⑨ ⑩ ⑪ ⑫ ⑬	∅ 40÷80	009 ... 8901F

METAL WORK S.p.A

Head office: Via Segni, 5-7-9 25062 - Concesio (Brescia) Italy - Tel. 030 21 87 11 - Fax 030 21 80 569  
www.metalwork.it - metalwork@metalwork.it

The dimensions shown in this catalogue are subject to variations at any time without prior notice