

PRECISION PRESSURE REGULATOR WITH HIGH EXHAUST FLOW, SERIE GS

GS is a series of precision regulators, designed for rapid relief of overpressure and a high flow rate.

They feature identical and opposing regulation valves on the inlet and outlet sides. This enables the regulator to behave symmetrically – precise regulation with a high rate of flow both in and out.

The pressure setting is virtually insensitive to changes in the upstream pressure (see diagram below), which guarantees accuracy even when the mains pressure fluctuates considerably.

A slight escape of air is required for correct operation of the regulator – it must not be considered a defect.

The regulator can be fixed using the through holes in the body or a bracket accessory.

The body has a 1/8" pressure gauge fitting.

GS regulators are suitable for applications requiring good accuracy in maintaining the pressure and a certain sensitivity in relieving pressure peaks, e.g. to supply low-friction cylinders, reel tensioners and coil winders. Two sizes of compressed air fitting are available: 1/8" and 1/4". Three different setting ranges are available: 0÷2 bar, 0÷4 bar and 0÷8 bar.



TECHNICAL DATA		
Threaded port		1/8" - 1/4"
Setting range		0÷2 bar - 0÷4 bar - 0÷8 bar
Max. input pressure	bar	10
Flow rate at 6.3 bar (0.63 MPa-91 psi) ΔP 0.5 bar (0.05 MPa – 7 psi)	NI/min	550
Flow rate at 6.3 bar (0.63 MPa-91 psi) ΔP 1 bar (0.1 MPa – 14 psi)	NI/min	680
Fluid		Unlubricated filtered air
		The air must be at least 10 μm pre-filtered
Max temperature	°C	50
Mounting position		In any position
Pressure gauge port		G 1/8"
Weight	gr	600
Exhaust flow rate at 4 bar (regulated pressure)		
ΔP 0,1 bar	NI/min	170
ΔP 0,5 bar	NI/min	370
Variation in regulated pressure (2 bar) with changes in upstream pressure (4-10 bar)	mbar	± 20
Relieving sensitivity	mbar	30
Air consumption – continuous escape	NI/min	< 0,1
Notes		The regulator pressure must always be set upwards. For increased sensitivity, use a pressure regulator with a rated pressure as close as possible to the required value. Do not take air from pressure gauge ports.

COMPONENTS

- ① Spring: stainless steel
- ② Cartridges: nickel-plated brass
- ③ Poppet: nickel-plated brass
- ④ Ring: vulcanized NBR
- ⑤ Control lever: brass
- ⑥ Bodies: painted aluminium
- ⑦ Control diaphragm: oil-proof rubber
- ⑧ Filter: sintered bronze
- ⑨ Throttle cartridge: brass
- ⑩ Ball: stainless steel
- ⑪ Ball valve: brass
- ⑫ Regulation diaphragm: NBR
- ⑬ Ring nut: technopolymer
- ⑭ Adjusting spring: steel
- ⑮ Scroll: brass
- ⑯ Bell: technopolymer
- ⑰ Adjusting screw: brass
- ⑱ Knob: technopolymer

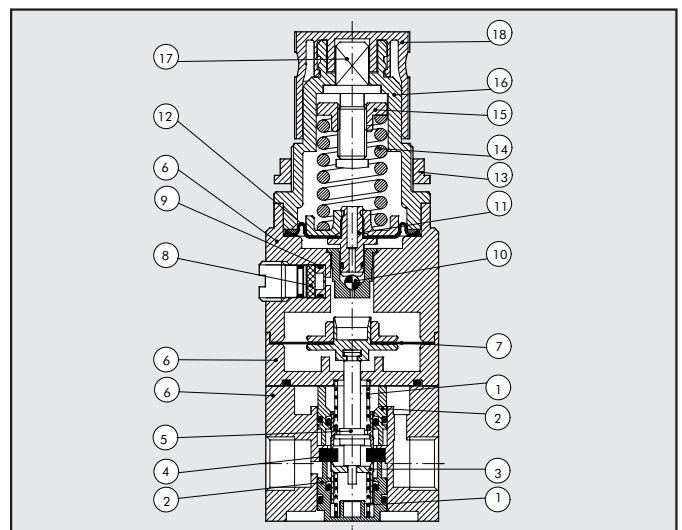

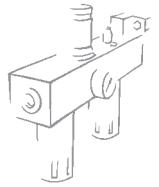

FLOW RATE

Upstream pressure = 7 bar

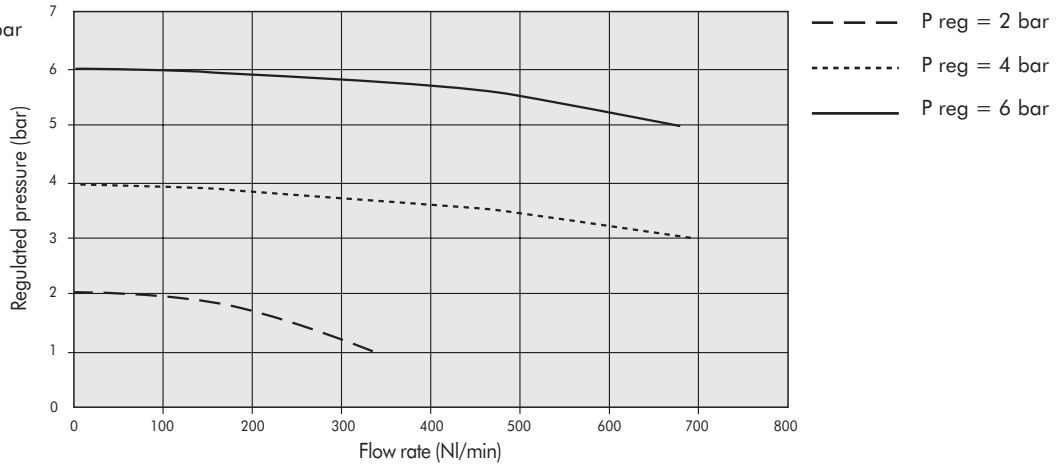

RELIEVING FLOW RATE

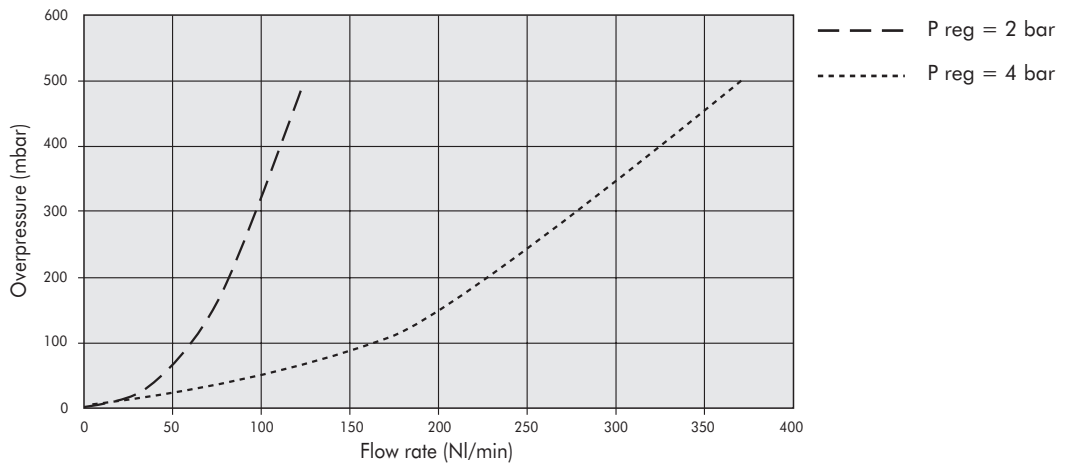

UPSTREAM PRESSURE SENSITIVITY

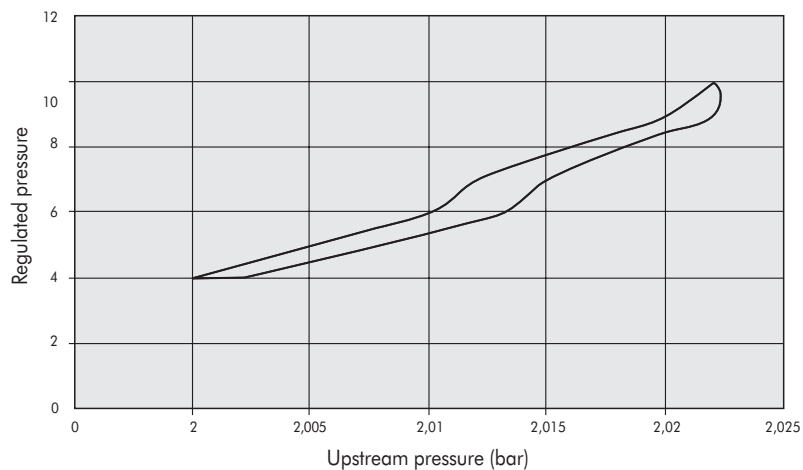

DIMENSIONS

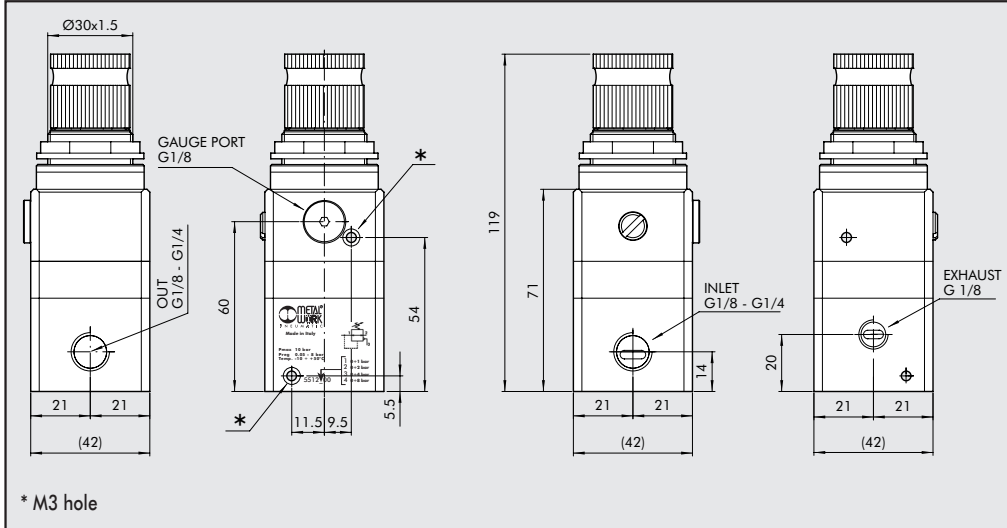

ORDERING CODES

Code	Description
5511200	REG. GS 1/8 02
5511300	REG. GS 1/8 04
5511400	REG. GS 1/8 08
5512200	REG. GS 1/4 02
5512300	REG. GS 1/4 04
5512400	REG. GS 1/4 08

ACCESSORIES

R/FR FIXING BRACKET

Code Description

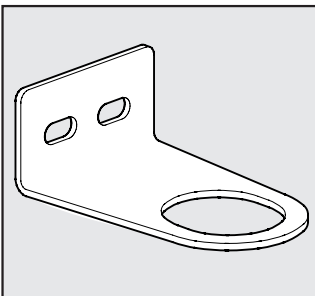

9200701 ACC. SF100 - BIT - ND 1/4

PRESSURE GAUGE

Code Description

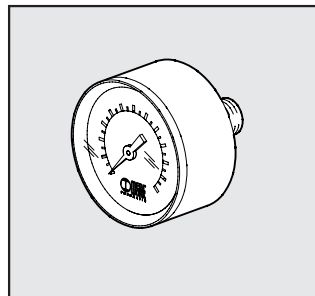

9700102 ACC.M 40 1/8 04
9700101 ACC.M 40 1/8 12

SPARES

UPPER COVER FOR MR

Code Description

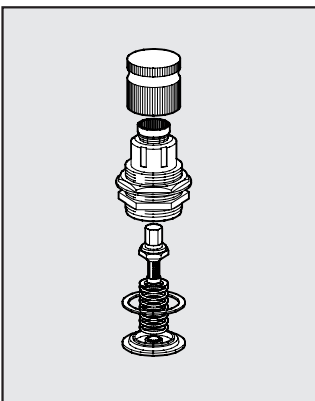

9250835 SPARES CS REG GS 02
9250836 SPARES CS REG GS 04
9250837 SPARES CS REG GS 04

NOTES

METAL WORK S.p.A

Head office: Via Segni, 5-7-9 25062 - Concesio (Brescia) Italy - Tel. 030 21 87 11 - Fax 030 21 80 569
www.metalwork.it - metalwork@metalwork.it

The dimensions shown in this catalogue are subject to variations at any time without prior notice