

IN-LINE PROGRESSIVE STARTER VAP 1/4" AND 1/2"

The in-line progressive starter is a valve that regulates the flow of air until the inlet pressure reaches a certain value, at which the valve opens and allows air to flow at full rate. This valve can be used to control a group of valves or a single valve, or it can be mounted between another valve and an actuator. The air that enters inlet 1 passes through a choke that has a knob adjustment to control the flow. The valve opens completely when the outlet pressure reaches about 60% of the inlet pressure. If the air supply is switched off, the valve discharges air from outlet 2 to inlet 1.



TECHNICAL DATA	VAP 1/4	VAP 1/2
Threaded ports	1/4"	1/2"
Type of valve		2/2 NC
Minimum operating pressure	bar	2
	psi	29
	Mpa	0.2
Maximum operating pressure	bar	10
	psi	145
	Mpa	1
Switching pressure	about 60% of inlet pressure	
Operating frequency	Max. 5	
Flow rate at 6.3 bar, Δp=0.5 bar:	Nl/min	2350
	scfm	83
Flow rate at 6.3 bar, Δp=1 bar:	Nl/min	3100
	scfm	110
Maximum flow rate through flow regulator at 6.3 bar:	Nl/min	300
	scfm	11
Operating temperature	-10 to +70	
	14 to 158	
Fluid	Filtered, lubricated or unlubricated, compressed air. Lubrication, if used, must be continuous.	
Weight	g	220
Wall fixing screws	Min. M4x25	Min. M4x35
Mounting	in any position	

COMPONENTS

- ① BODY: anodized aluminium
- ② BALL: steel
- ③ INSERT: nickel-plated brass
- ④ O-Ring: NBR
- ⑤ POPPET: NBR
- ⑥ PISTON: anodized aluminium
- ⑦ PISTON GASKET: NBR
- ⑧ O-Ring: NBR
- ⑨ SPRING : steel
- ⑩ PIN: nickel-plated brass
- ⑪ NUT: nickel-plated brass
- ⑫ PIN HOLDER: nickel-plated brass
- ⑬ SNAP RING: galvanized steel

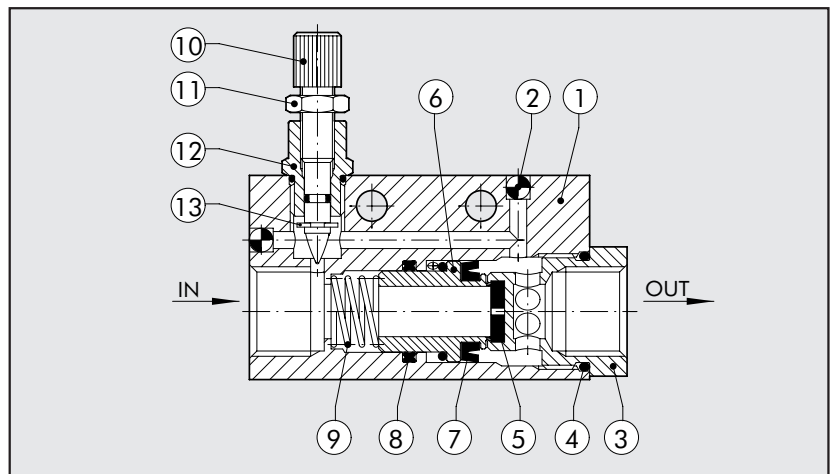

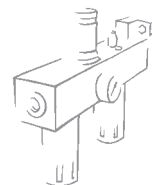

OPERATION

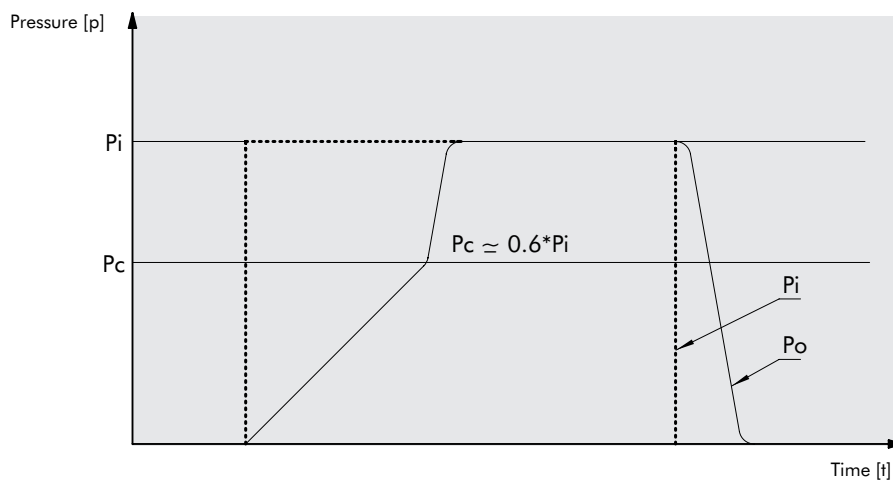

P_i = inlet pressure
 P_o = outlet pressure
 P_c = switching pressure

DIMENSIONS

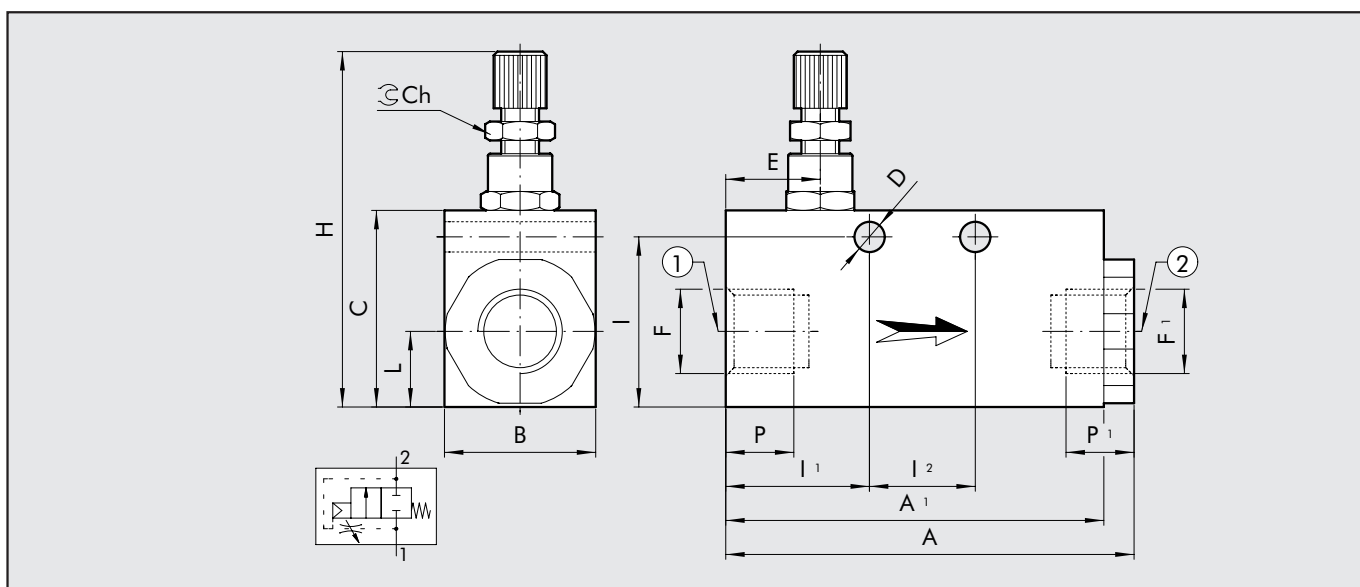

Code	Description	F	F ¹	A	A ¹	B	C	D	E	H	I	I ¹	I ²	L	P	P ¹
W360600002	VAP 1/4	G 1/4	G 1/4	56	50	20	30	4.5	10	49÷52	25.5	18	16	10	9	9
W360600004	VAP 1/2	G 1/2	G 1/2	75.8	65	30	40	4.5	13	59÷62	35.5	26.5	16	15	12	12

METAL WORK S.p.A

Head office: Via Segni, 5-7-9 25062 - Concesio (Brescia) Italy - Tel. 030 21 87 11 - Fax 030 21 80 569
www.metalwork.it - metalwork@metalwork.it

The dimensions shown in this catalogue are subject to variations at any time without prior notice