

The assembly surface dimensions of ISO1, ISO2 and ISO 3 valves are to ISO5599-1. They are available in the 5-way versions with 2 and 3 positions and with pneumatic or solenoid actuation.

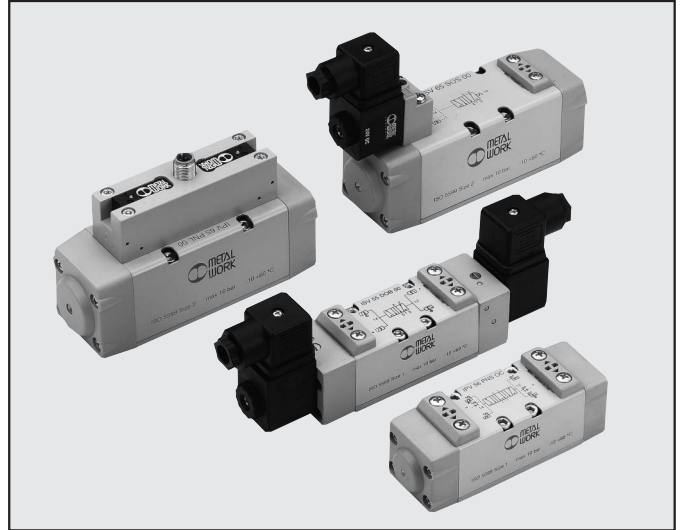

TECHNICAL DATA	ISO 1	ISO 2	ISO 3
Fluid	Filtered air without lubrication; lubrication, if used, must be continuous		
Operating pressure:			
• monostable	Vacuum ÷ 10 bar pneumatic – 2.5 ÷ 10 bar solenoid/pneumatic		
• bistable	Vacuum ÷ 10 bar pneumatic – 1 ÷ 10 bar solenoid/pneumatic		
• pilot-assisted	Vacuum ÷ 10 bar		
Minimum pilot pressure	2.5 bar		
Operating temperature range	-10° ÷ +60°C		
Nominal diameter	7.5 mm	12 mm	15 mm
Conductance C	250 NI/min · bar	657.14 NI/min · bar	971.43 NI/min · bar
Critical ratio b	0.36 bar/bar	0.25 bar/bar	0.43 bar/bar
Flow rate at 6 Bar ΔP 0.5 Bar	700 NI/min	1800 NI/min	3200 NI/min
Flow rate at 6 Bar ΔP 1 Bar	1100 NI/min	2700 NI/min	4600 NI/min
Installation	In any position (vertical assembly is not recommended for bistable valves subjected to vibration)		
Assembly	On single and manifold bases according to ISO 5599/1		
Recommended lubricant	ISO and UNI FD 22		
Solenoid pilot:	to CNOMO / in-line pilot / M12		to CNOMO
Manual:	bistable on solenoid pilot monostable on valve body		
Maximum torque nut/coil	1 Nm		
Compatibility with oils:	see GENERAL CATALOGUE page 6.1/08 or webpage <a href="http://www.metalwork.it/eng/materiali_compatibilita.html">www.metalwork.it/eng/materiali_compatibilita.html</a>		

## COMPONENTS

- ① VALVE BODY: Aluminium
- ② END CAP: HOSTAFORM®
- ③ SPOOL: chemically nickel-plated aluminium
- ④ DISTANCE PLATES: plastic
- ⑤ GASKETS: NBR nitrile rubber
- ⑥ PISTONS: HOSTAFORM®
- ⑦ PISTON GASKETS: NBR nitrile rubber
- ⑧ FILTER: sintered bronze
- ⑨ SPRINGS: special steel
- ⑩ OPERATOR: Brass pipe – Stainless steel core

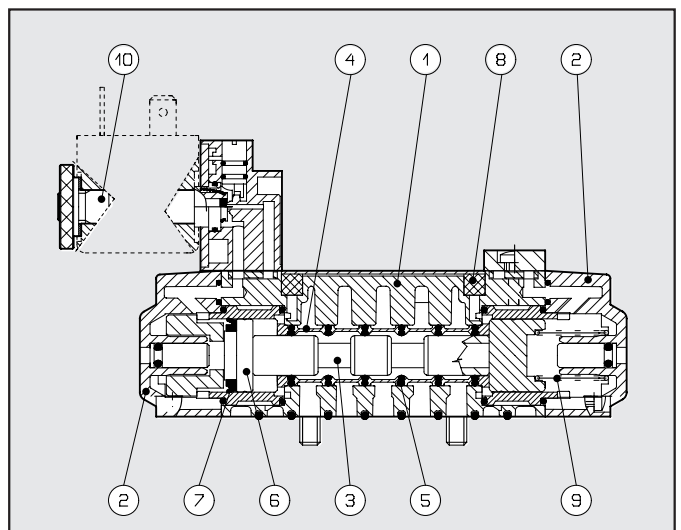

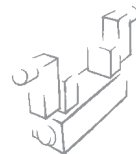

## FLOW CHARTS ISO 1

### ISO 1

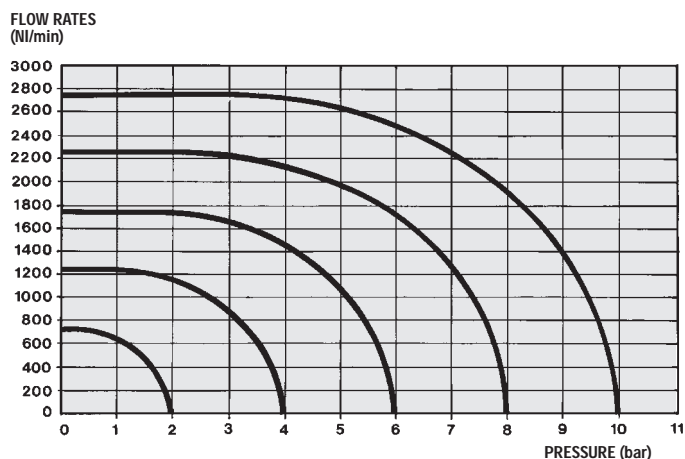

### ISO 2

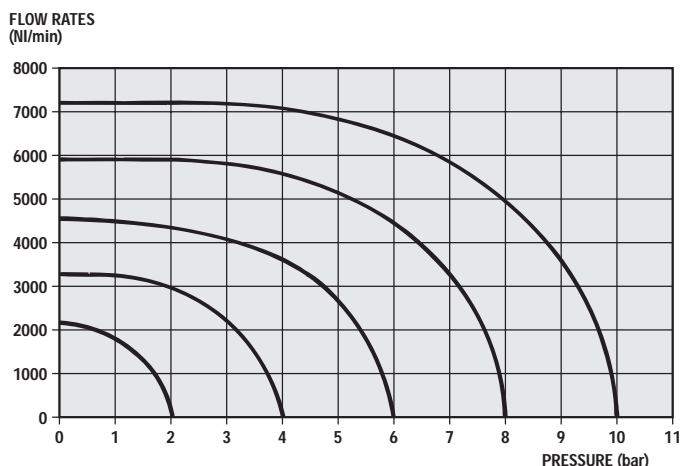

### ISO 3

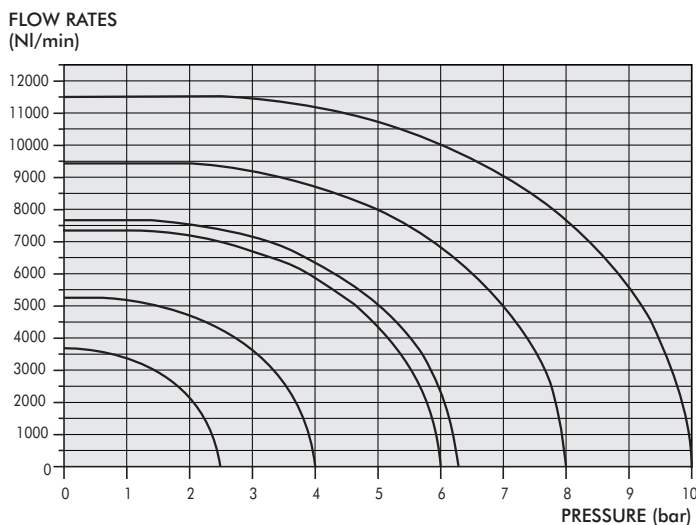

## KEY TO CODES

I	P	V	5	5	P	N	S	O	O		
FAMILY		PORT		FUNCTION		OPERATORS 14		RESETTING 12		FURTHER DETAILS	
IPV	ISO pneumatic	5	ISO 1	5	5/2	PN	pneumatic	S	mechanical	OO	5/2
ISV	ISO solenoid/ pneumatic	6	ISO 2	6	5/3	SO	solenoid/pneumatic		spring	CC	closed centres
		7	ISO 3			SE	electric pilot-assisted	B	bistable	OC	open centres
						* DO	solenoid/pneumatic in line	D	differential	PC	pressure centres
						* DE	solenoid, assisted in line				
						* CO	M12 solenoid/pneumatic				
						* CE	M12 solenoid assisted				

\* only for ISO 1 and ISO 2



# VALVES ISO 5599/1, PNEUMATIC SERIES IPV

TECHNICAL DATA	ISO 1	ISO 2	ISO 3
Operating pressure	Vacuum ÷ 10 bar		
Minimum operation pressure:			
• monostable	2.5 bar		
• bistable	1 bar		
Operating temperature range	-10° to 60°C		
Nominal diameter	7.5 mm	12 mm	15 mm
Conductance C	250 NI/min · bar	657.14 NI/min · bar	971.43 NI/min · bar
Critical ratio b	0.36 bar/bar	0.25 bar/bar	0.43 bar/bar
Flow rate at 6 Bar ΔP 0.5 Bar	700 NI/min	1800 NI/min	3200 NI/min
Flow rate at 6 Bar ΔP 1 Bar	1100 NI/min	2700 NI/min	4600 NI/min
Response times at 6 Bar:			
• monostable	12 ms	24 ms	35 ms
• bistable	20 ms	30 ms	45 ms
Repositioning response times at 6 Bar:			
• monostable	30 ms	43 ms	55 ms
• bistable	20 ms	30 ms	45 ms
Manual	monostable on valve body		



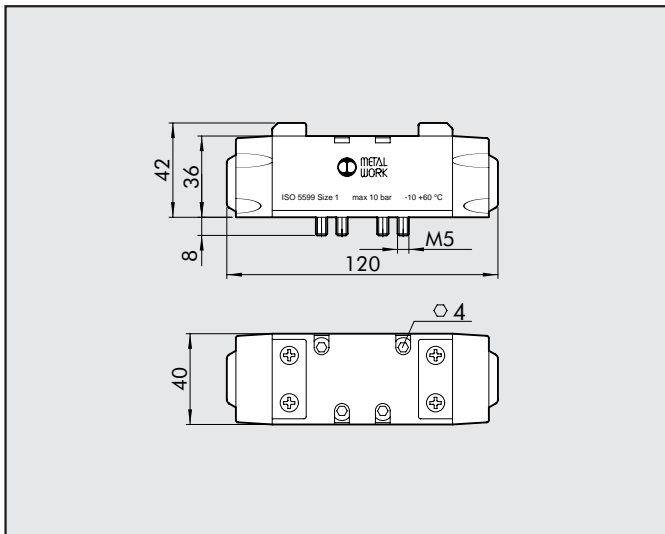

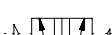
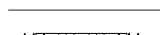
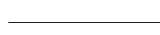
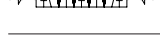

## PNEUMATIC ACTUATION ISO 1

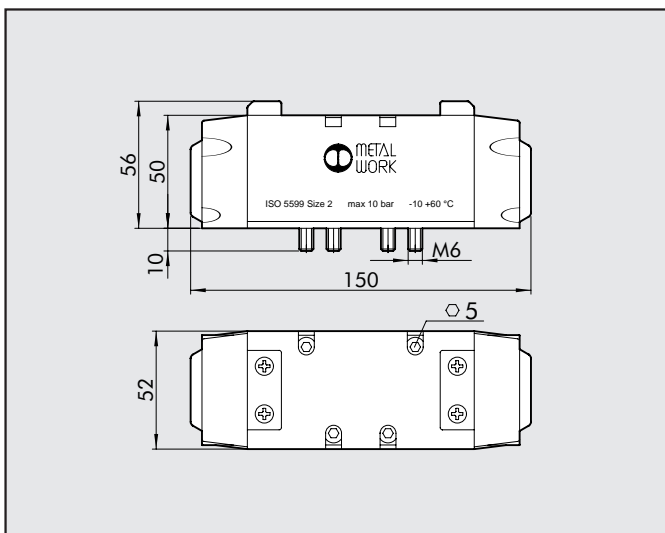

Symbol	Abbrev.	Code	Weight [g]
	IPV 55 PNS OO	7051011100	310
	IPV 55 PNB OO	7051012200	310
	IPV 55 PND OO	7051013300	310
	IPV 56 PNS CC	7051021200	310
	IPV 56 PNS OC	7051022200	310
	IPV 56 PNS PC	7051023300	310

## PNEUMATIC ACTUATION ISO 2

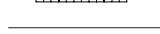
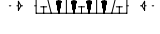

Symbol	Abbrev.	Code	Weight [g]
	IPV 65 PNS OO	7052011100	705
	IPV 65 PNB OO	7052012200	705
	IPV 65 PND OO	7052013300	705
	IPV 66 PNS CC	7052021200	705
	IPV 66 PNS OC	7052022200	705
	IPV 66 PNS PC	7052023300	705

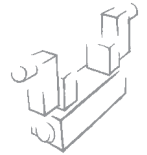

## PNEUMATIC ACTUATION ISO 3

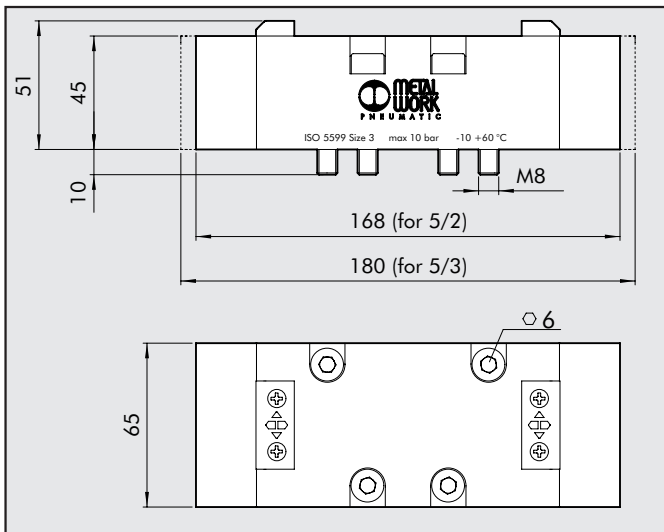

Symbol	Abbrev	Code	Weight [g]
	IPV 75 PNS OO	7056011100	1175
	IPV 75 PNB OO	7056011200	1175
	IPV 75 PND OO	7056011300	1175
	IPV 76 PNS CC	7056012100	1290
	IPV 76 PNS OC	7056012200	1290
	IPV 76 PNS PC	7056012300	1290







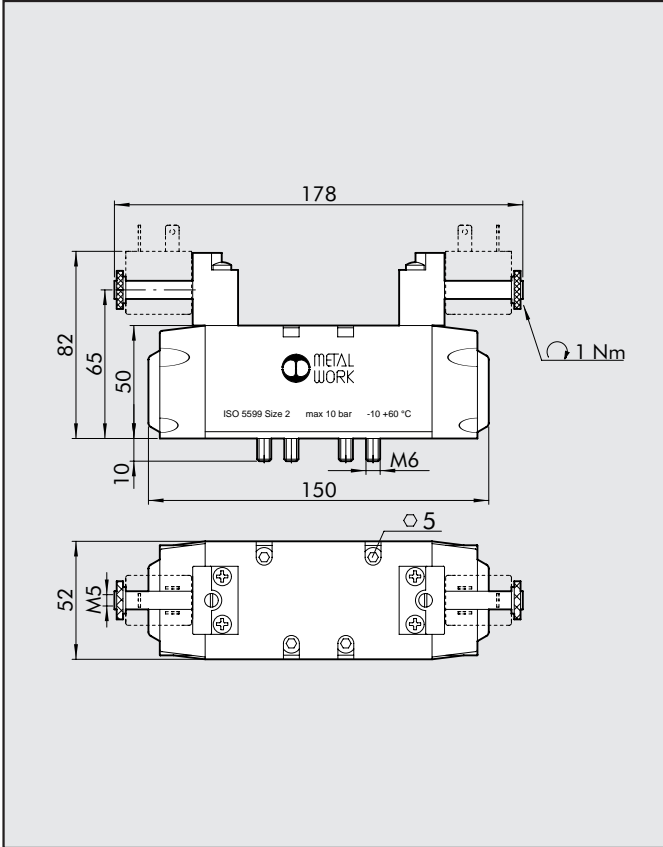

## NOTES





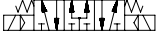

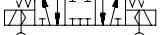

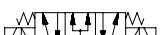

**BISTABLE 5/2 ISO 2  
MONOSTABLE 5/3 ISO 2**

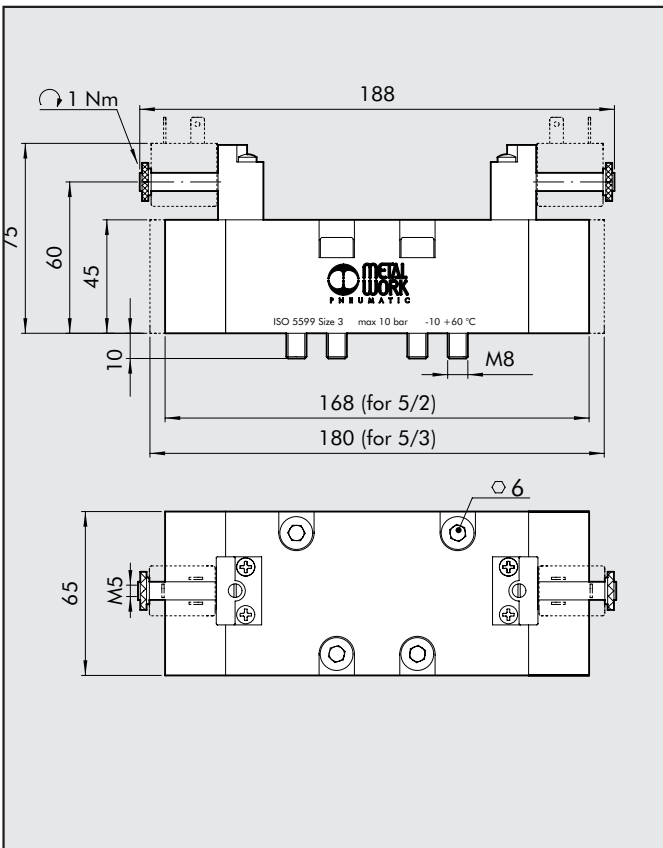

Symbol	Abbrev	Code	Weight [g]
	ISV 65 SOB OO	7052021200	740
	ISV 65 SOD OO	7052021300	710
	ISV 66 SOS CC	7052022100	720
	ISV 66 SOS OC	7052022200	720
	ISV 66 SOS PC	7052022300	720
	ISV 65 SEB OO	7052021500	740
	ISV 65 SED OO	7052021600	710
	ISV 66 SES CC	7052022400	720
	ISV 66 SES OC	7052022500	720
	ISV 66 SES PC	7052022600	720

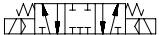
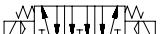
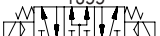
**BISTABLE 5/2 ISO 3  
MONOSTABLE 5/3 ISO 3**

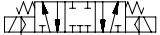

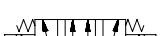
Symbol	Abbrev	Code	Weight [g]
	ISV 75 SOB OO	7056021200	1230
	ISV 75 SOD OO	7056021300	1230
	ISV 76 SOS CC	7056022100	1355
	ISV 76 SOS OC	7056022200	1355
	ISV 76 SOS PC	7056022300	1355
	ISV 75 SEB OO	7056021500	1230
	ISV 75 SED OO	7056021600	1230
	ISV 76 SES CC	7056022400	1355
	ISV 76 SES OC	7056022500	1355
	ISV 76 SES PC	7056022600	1355





# COILS AND CONNECTORS FOR ISO 5599/1 SOLENOID VALVES SERIES ISV

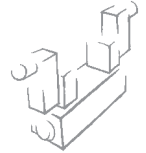

## COILS SIDE 22 mm FOR ISO 5599/1 SOLENOID VALVES

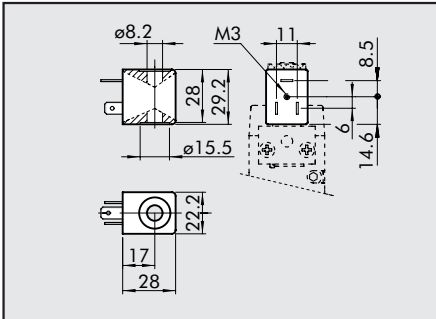

- Voltage tolerance: -10% + 15%
- Insulation class: F155
- Degree of protection: IP65 EN60529 with connector
- Avoid prolonged exposure to the atmospheric agents
- Coil temperature 100% ED: 70°C at 20°C – Ambient temperature
- According to Atex 94/9 CE rule, group 2, category 3 GD

Nominal voltage	Absorption		Abbrev.	Code
	Inrush	Holding		
12Vcc	2W	2W	Coil 22 Ø8 BA 2W-12VDC	W0215000151
24Vcc	2W	2W	Coil 22 Ø8 BA 2W-24VDC	W0215000101
24V 50/60Hz	5.3VA	3.5VA	Coil 22 Ø8 BA 3.5VA-24VAC	W0215000111
110V 50/60Hz	5.3VA	3.5VA	Coil 22 Ø8 BA 3.5VA-110VAC	W0215000121
220V 50/60Hz	5.3VA	3.5VA	Coil 22 Ø8 BA 3.5VA-220VAC	W0215000131

## COILS SIDE 30 mm

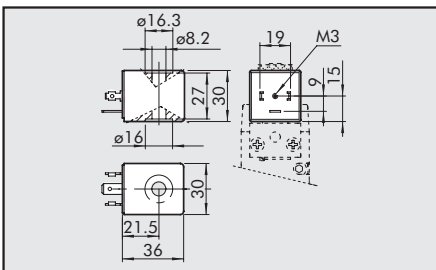

- electric contact DIN43650 shape A – ISO 4400
- Voltage tolerance: -10% + 10%
- Insulation class: F155
- Degree of protection: IP65 EN60529 with connector
- Avoid prolonged exposure to the atmospheric agents
- According to Atex 94/9 CE rule, group 2, category 3 GD

Nominal voltage	Absorption		Abbrev.	Code
	Inrush	Holding		
24Vcc	5W	4W	Coil 30 Ø8 4W-24VDC	W0210010100
24V 50/60Hz	10VA	4VA	Coil 30 Ø8 4VA-24VAC	W0210011100
110V 50/60Hz	10VA	4VA	Coil 30 Ø8 4VA-110VAC	W0210012100
220V 50/60Hz	10VA	4VA	Coil 30 Ø8 4VA-220VAC	W0210013100

## CONNECTOR FOR COILS SIDE 22 mm

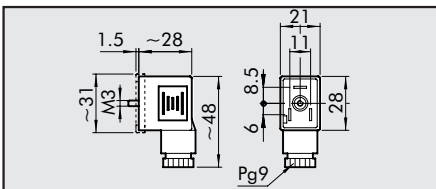

Colour	Ø Cable	Type	Code
Black	PG9	Standard	W0970510011
Transparent	PG9	LED 24V	W0970510012
Transparent	PG9	LED 110V	W0970510013
Transparent	PG9	LED 220V	W0970510014
Transparent	PG9	LED + VDR 24V	W0970510015
Transparent	PG9	LED + VDR 110V	W0970510016
Transparent	PG9	LED + VDR 220V	W0970510017

## CONNECTOR FOR COILS SIDE 30 mm

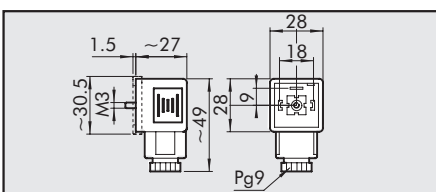

Colour	Ø Cable	Type	Code
Black	PG9	Standard	W0970520033
Transparent	PG9	LED 24V	W0970520034
Transparent	PG9	LED 110V	W0970520035
Transparent	PG9	LED 220V	W0970520036
Transparent	PG9	LED + VDR 24V	W0970520037
Transparent	PG9	LED + VDR 110V	W0970520038
Transparent	PG9	LED + VDR 220V	W0970520039

## KIT COIL EEXM

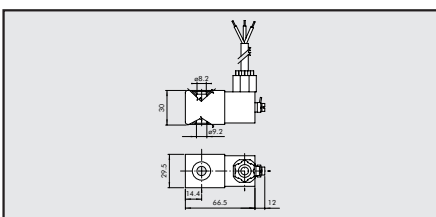

Code	Description
0227606913	KIT FOR COIL 30 24 VDC EEXMT5 CABLE 3M
0227606915	KIT FOR COIL 30 24 VDC EEXMT5 CABLE 5M
0227608013	KIT FOR COIL 30 24 VAC EEXMT5 CABLE 3M
0227608015	KIT FOR COIL 30 24 VAC EEXMT5 CABLE 5M
0227608023	KIT FOR COIL 30 110 VAC EEXMT5 CABLE 3M
0227608025	KIT FOR COIL 30 110 VAC EEXMT5 CABLE 5M
0227608033	KIT FOR COIL 30 230 VAC EEXMT5 CABLE 3M
0227608035	KIT FOR COIL 30 230 VAC EEXMT5 CABLE 5M

according to Atex 94/9 CE rule, group 2, category 2 GD

## KIT COILS SIDE 22 IP65



Code	Description
0222100100	KIT FOR COILS 22 - IP65

Improved IP65 protection, even after prolonged exposure to atmospheric agents.  
Applicable to valves with a technopolymer control.



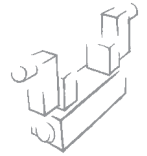

**BISTABLE 5/2 ISO 1  
MONOSTABLE 5/3 ISO 1**

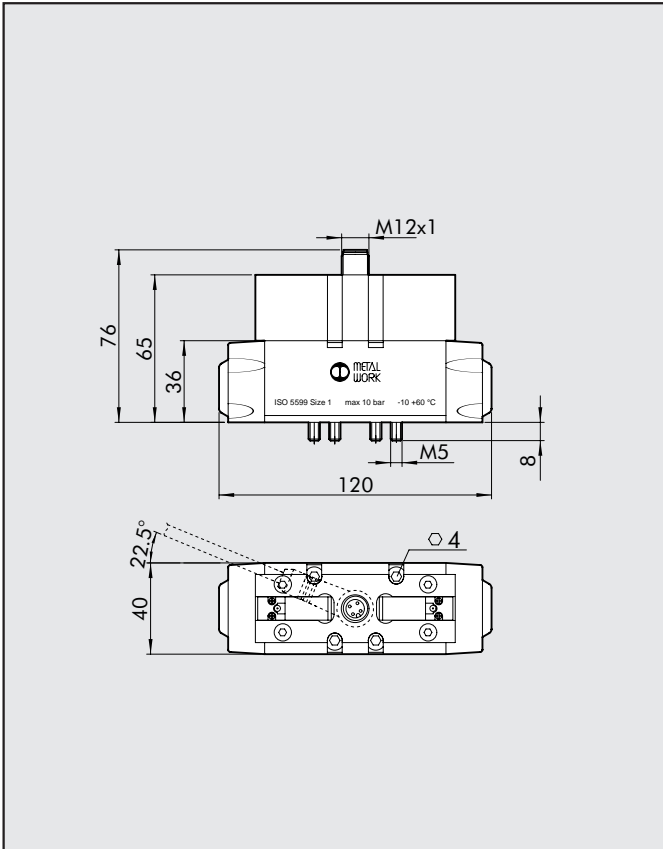

Symbol	Abbrev.	Code	Weight [g]
	ISV 55 COB OO	7054021200	512
	ISV 55 COD OO	7054021300	490
	ISV 56 COS CC	7054022100	496
	ISV 56 COS OC	7054022200	496
	ISV 56 COS PC	7054022300	496
	ISV 55 CEB OO	7054021500	512
	ISV 55 CED OO	7054021600	490
	ISV 56 CES CC	7054022400	496
	ISV 56 CES OC	7054022500	496
	ISV 56 CES PC	7054022600	496

**BISTABLE 5/2 ISO 2  
MONOSTABLE 5/3 ISO 2**

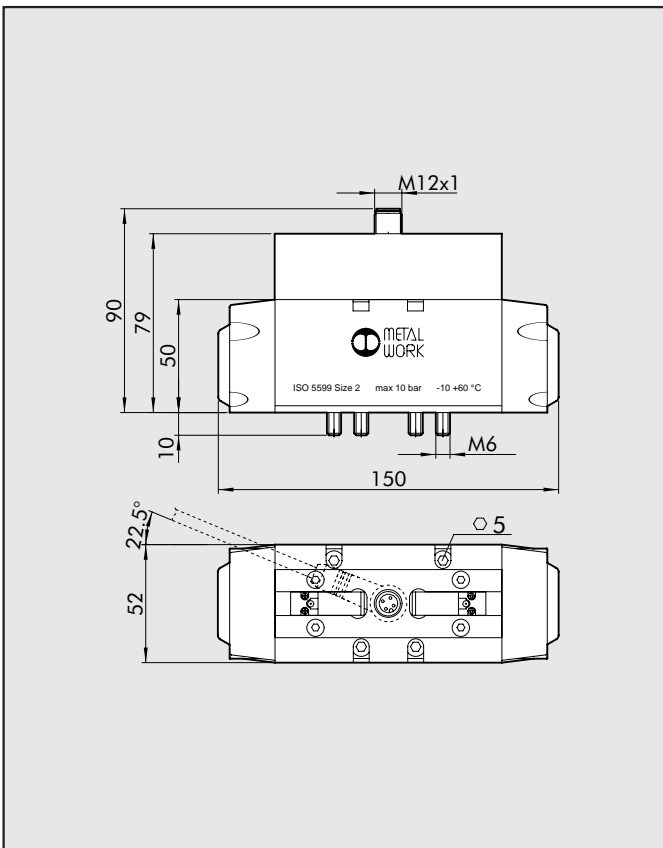

Symbol	Abbrev.	Code	Weight [g]
	ISV 65 COB OO	7055021200	860
	ISV 65 COD OO	7055021300	860
	ISV 66 COS CC	7055022100	868
	ISV 66 COS OC	7055022200	868
	ISV 66 COS PC	7055022300	868
	ISV 65 CEB OO	7055021500	860
	ISV 65 CED OO	7055021600	860
	ISV 66 CES CC	7055022400	868
	ISV 66 CES OC	7055022500	868
	ISV 66 CES PC	7055022600	868



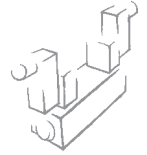

# BASES TO ISO 5599/1 FOR ISO 5599/1 VALVES SERIES IPV-ISV SIZE ISO1 AND ISO2

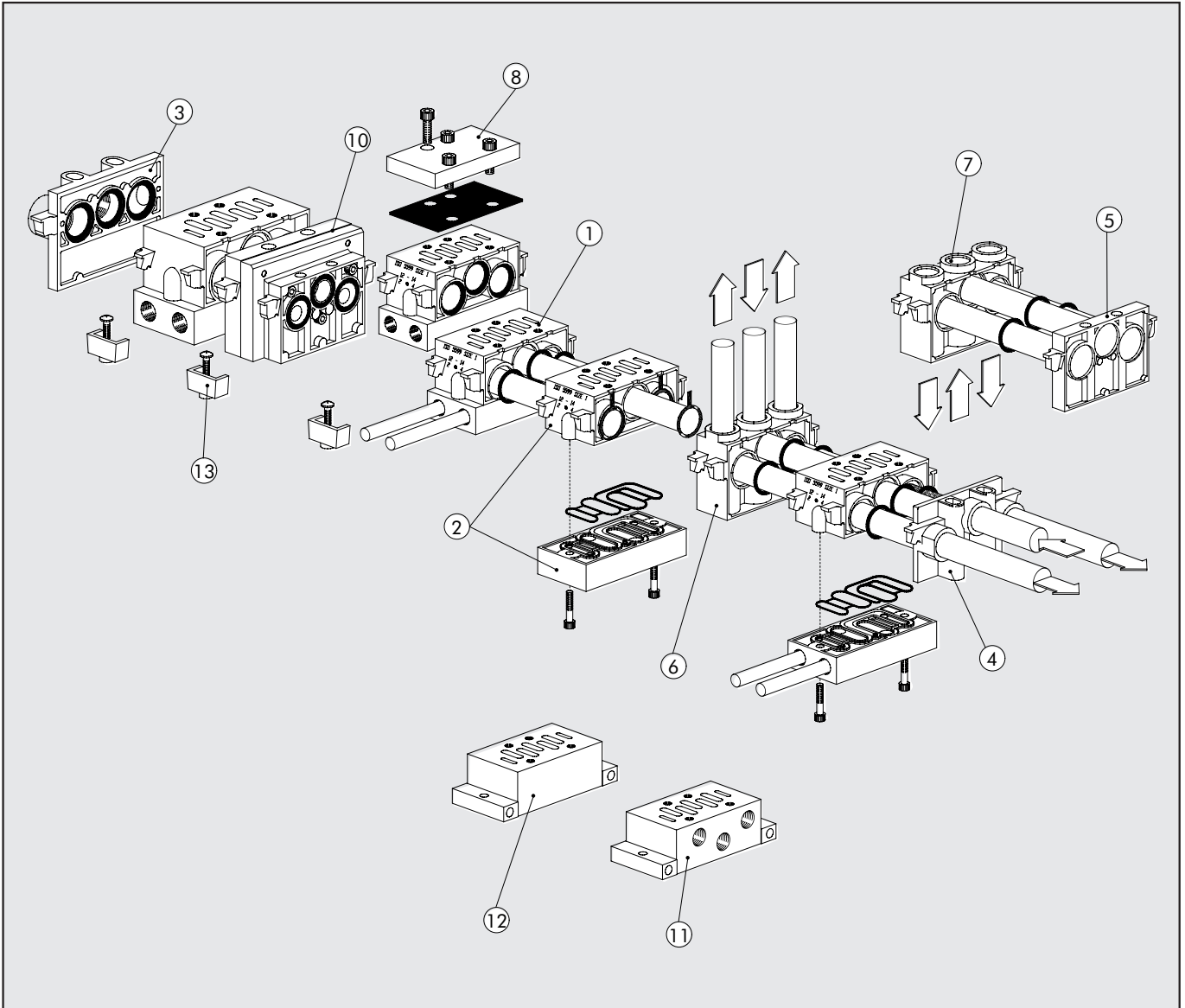

Ref.	Description	ISO 1 Code	ISO 2 Code
①	Manifold base – side ports	0228000150	0228001150
②	Manifold base with bottom ports	0228000155	0228001155
③	Input end plate	0228000200	0228001200
④	Additional input end plate	0228000201	0228001201
⑤	Blind end plate	0228000210	0228001210
⑥	Intermediate – top ports	0228000300	0228001300
⑦	Intermediate – back ports	0228000301	0228001301
⑧	Blanking plate	0228000500	0228001500
⑨	Intermediate diaphragm	0228000400	0228001400
⑩	ISO 1/ISO 2 port adapter	0228000600	-
⑪	Individual base – side ports	0228000100	0228001100
⑫	Base – bottom ports	0228000110	0228001110
⑬	Assembly kit	0228000700	0228001700

**MANIFOLD BASE, SIDE PORTS**

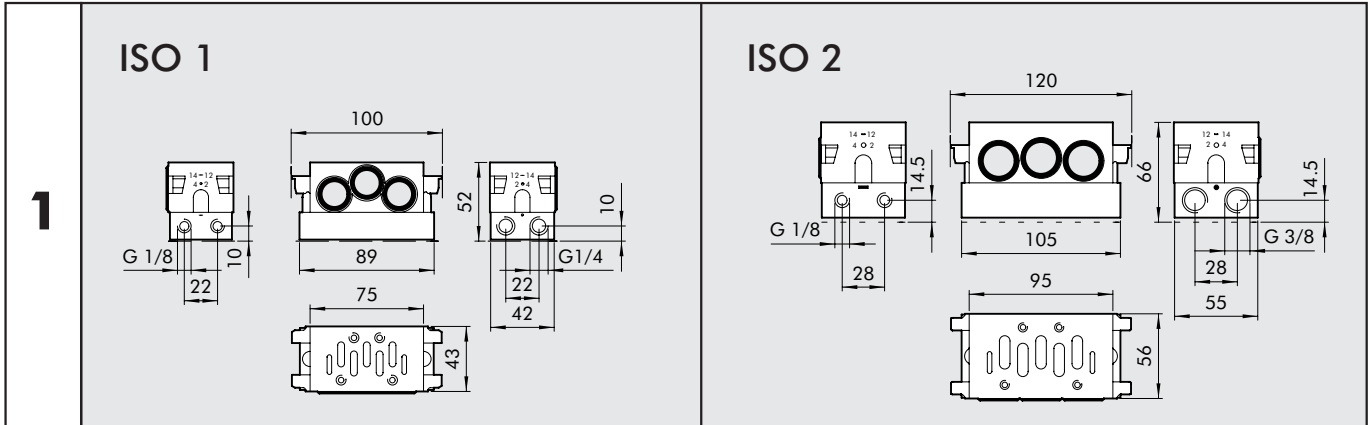

Code	Description	Weight [g]
0228000150	MANIFOLD BASE, SIDE PORTS, ISO 1	314
0228001150	MANIFOLD BASE, SIDE PORTS, ISO 2	131

**MANIFOLD BASE, BOTTOM PORTS**

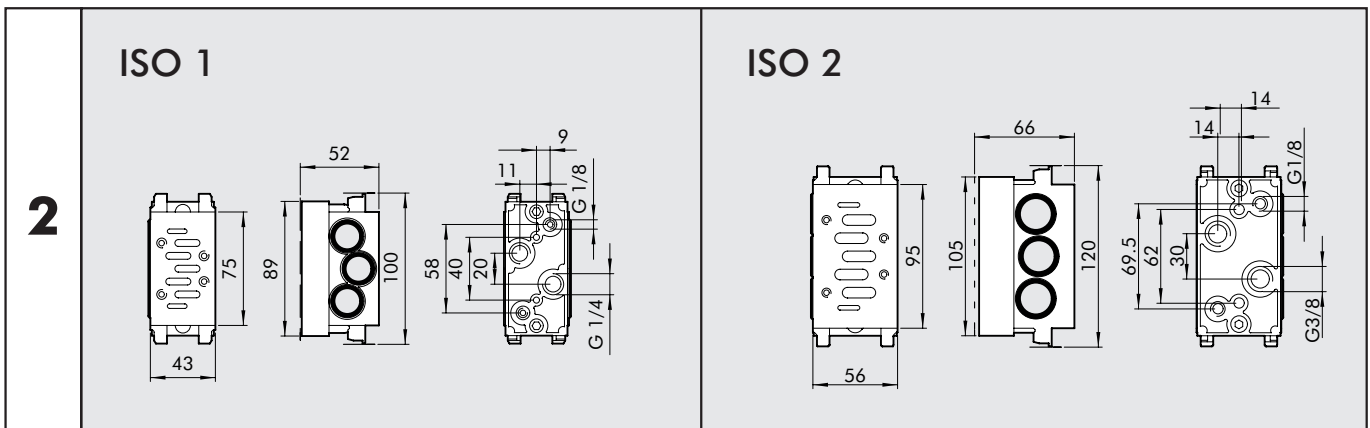

Code	Description	Weight [g]
0228000155	MANIFOLD BASE, BOTTOM PORTS, ISO 1	314
0228001155	MANIFOLD BASE, BOTTOM PORTS, ISO 2	505

**INPUT END PLATE**

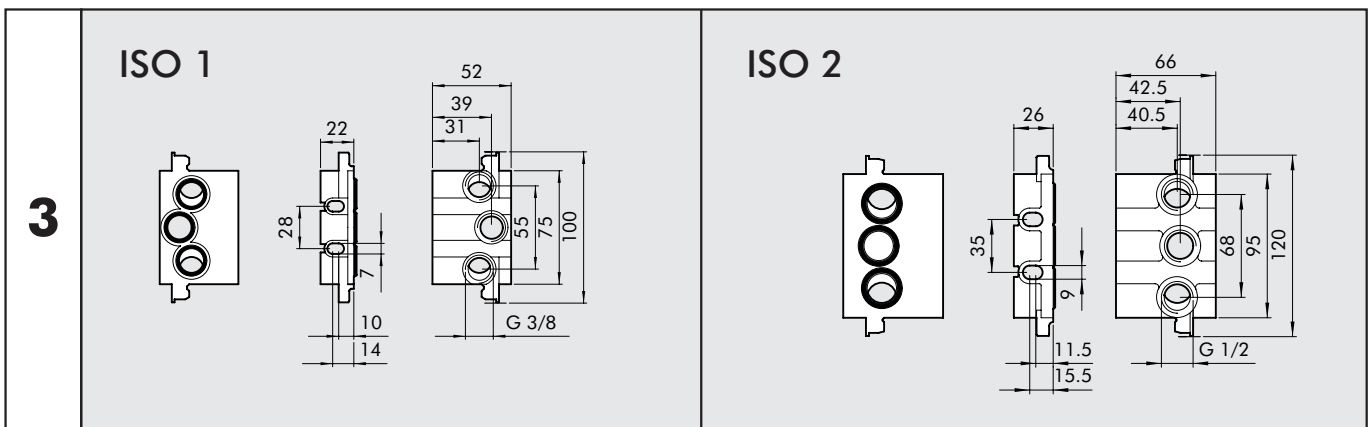

Code	Description	Weight [g]
0228000200	INPUT END PLATE TIN-1, ISO 1	129
0228001200	INPUT END PLATE TIN-1, ISO 2	206

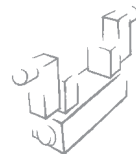

## ADDITIONAL INPUT END PLATE

<b>4</b>	ISO 1	ISO 2

Code	Description	Weight [g]
0228000201	ADDITIONAL INPUT END PLATE, ISO 1	84
0228001201	ADDITIONAL INPUT END PLATE, ISO 2	162

## BLIND END PLATE

<b>5</b>	ISO 1	ISO 2

Code	Description	Weight [g]
0228000210	BLIND END PLATE, ISO 1	79
0228001210	BLIND END PLATE, ISO 2	130

## INTERMEDIATE TOP PORTS

<b>6</b>	ISO 1	ISO 2

Code	Description	Weight [g]
0228000300	INTERMEDIATE TOP PORTS, ISO 1	235
0228001300	INTERMEDIATE TOP PORTS, ISO 2	299

### INTERMEDIATE REAR PORTS

<b>7</b>	ISO 1	ISO 2
		

Code	Description	Weight [g]
0228000301	INTERMEDIATE REAR PORTS, ISO 1	237
0228001301	INTERMEDIATE REAR PORTS, ISO 2	299

### BLANKING PLATE

<b>8</b>	ISO 1	ISO 2
		

Cod8	Description	Weight [g]
0228000500	BLANKING PLATE, ISO 1	47
0228001500	BLANKING PLATE, ISO 2	96

### INTERMEDIATE DIAPHRAGM

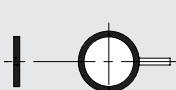
<b>9</b>		
----------	---	--

Code	Description	Weight [g]
0228000400	INTERMEDIATE DIAPHRAGM, ISO 1	4
0228001400	INTERMEDIATE DIAPHRAGM, ISO 2	7

### DIMENSION ADAPTER

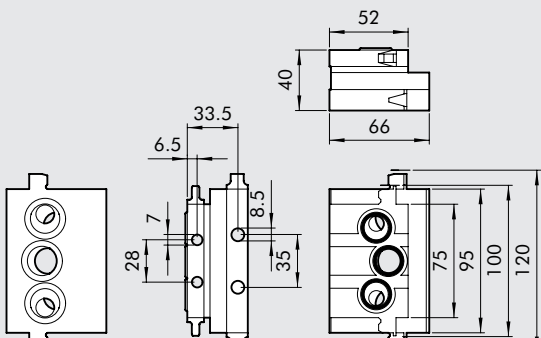
<b>10</b>		
-----------	--	--

Code	Description	Weight [g]
0228000600	DIMENSION ADAPTER ISO 1-2	454

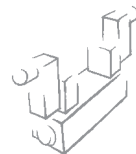

**INDIVIDUAL BASE SIDE PORTS**

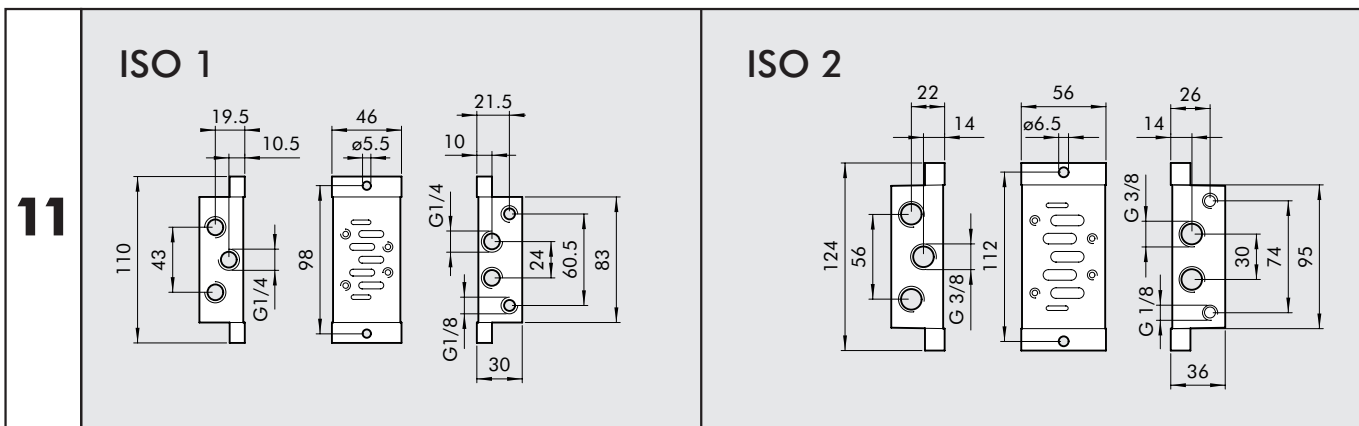

Code	Description	Weight [g]
0228000100	INDIVIDUAL BASE SIDE PORTS, ISO 1	165
0228001100	INDIVIDUAL BASE SIDE PORTS, ISO 2	257

**INDIVIDUAL BASE BOTTOM PORTS**

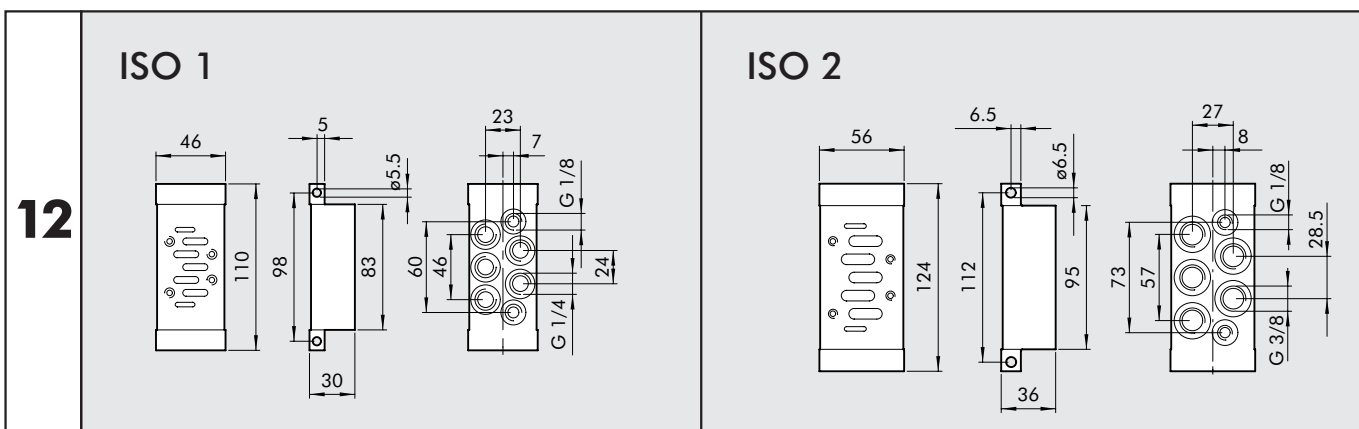

Code	Description	Weight [g]
0228000110	INDIVIDUAL BASE BOTTOM PORTS, ISO 1	197
0228001110	INDIVIDUAL BASE BOTTOM PORTS, ISO 2	304

**ASSEMBLY KIT**

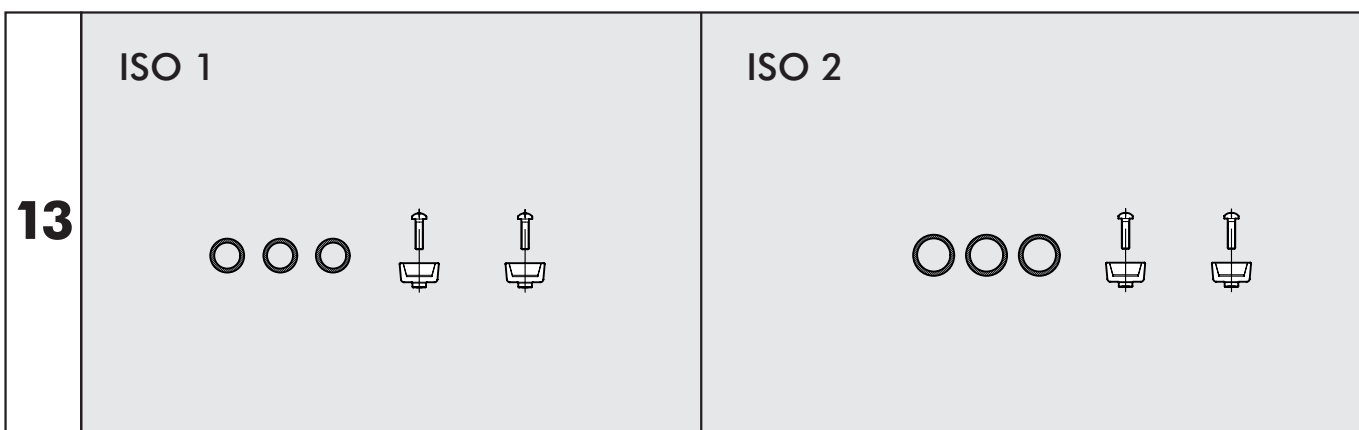

Code	Description	Weight [g]
0228000700	ASSEMBLY KIT, ISO 1	47
0228001700	ASSEMBLY KIT, ISO 2	47



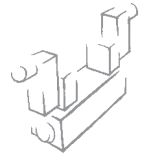

## MANIFOLD BASE, BOTTOM PORTS

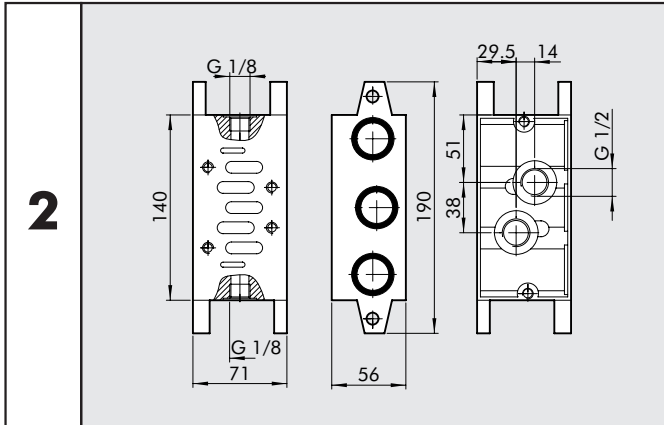

Code	Description	Weight [g]
0228002155	MANIFOLD BASE, BOTTOM PORTS, ISO 3	720

## INPUT END PLATE

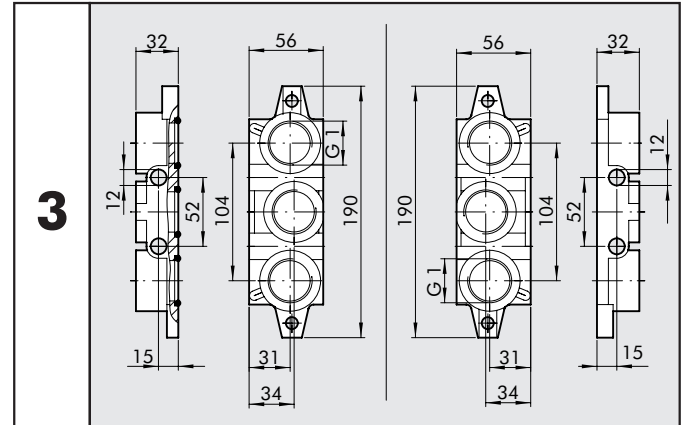

Code	Description	Weight [g]
0228002200	INPUT END PLATE, ISO 3	670

## BLANKING PLATE

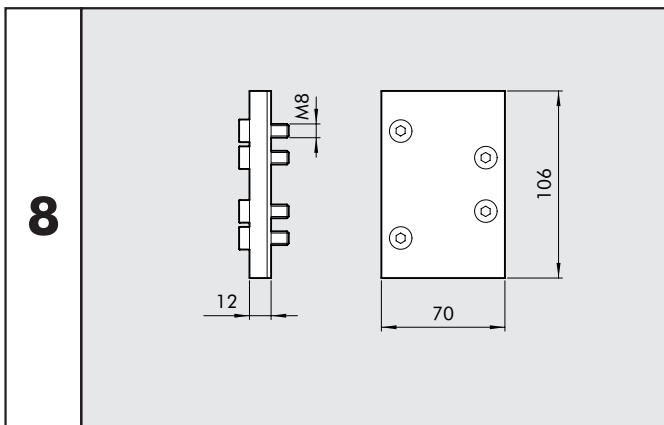

Code	Description	Weight [g]
0228002500	BLANKING PLATE, ISO 3	265

## INDIVIDUAL BASE SIDE PORTS

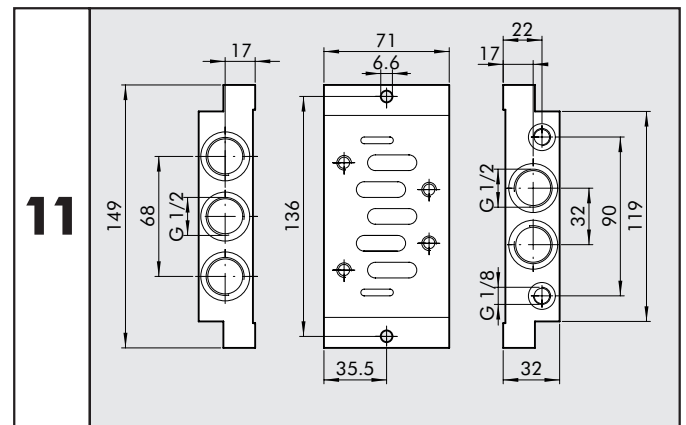

Code	Description	Weight [g]
0228002100	INDIVIDUAL BASE SIDE PORTS, ISO 3	360

## INDIVIDUAL BASE BOTTOM PORTS

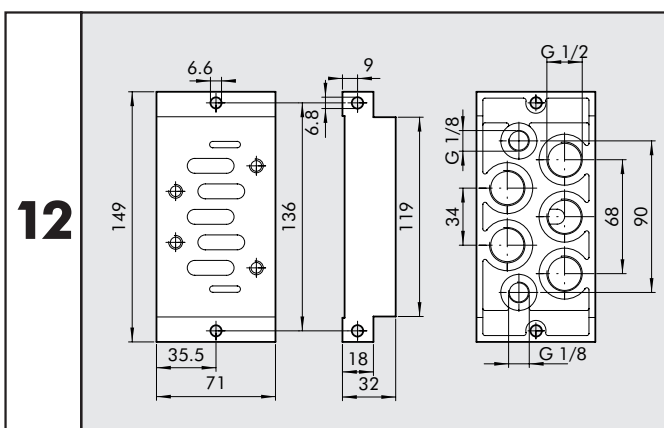

Code	Description	Weight [g]
0228002110	INDIVIDUAL BASE BOTTOM PORTS, ISO 3	420

## NOTES



# SANDWICH REGULATORS FOR ISO 5599/1 BASES ISO1-2

TECHNICAL DATA	ISO 1	ISO 2
Max upstream pressure	13 bar	
Pressure range	0 ÷ 12 bar	
Pressure gauge range	0 ÷ 12 bar	
Flow rate at 6 Bar ΔP 1 Bar	400 NI/min	550 NI/min
Operating temperature range	-10 ÷ +60°C	
Fixing screw on ISO 5599/1 base	M5 ant-extraction	M6 anti-extraction
Installation	in any position	
Instructions for use	Downstream pressure must always be set to increasing values	



## SANDWICH REGULATOR FOR ISO 1 VALVES

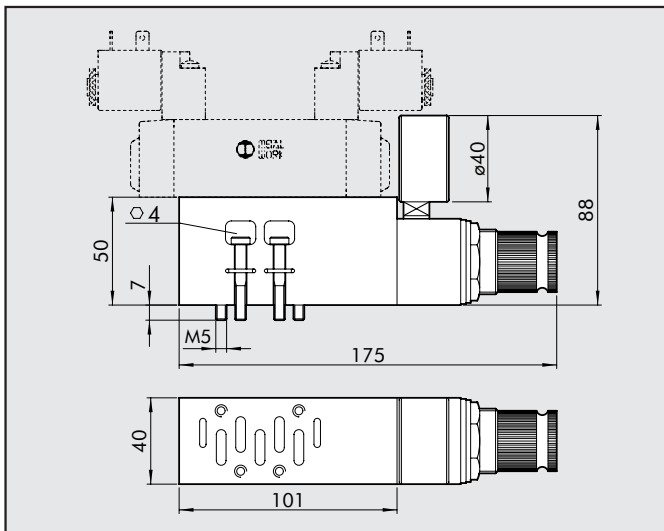

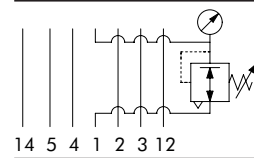
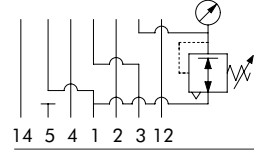
Symbol	Abbrev.	Code	Weight [g]
	0228000804	Sandwich regulator 1 0 ÷ 12 bar ISO 1	760
	0228000814*	Sandwich regulator 3 0 ÷ 12 bar ISO 1	760
*A pilot-assisted valve needs to be used since port 1 relieves pressure, it is not under pressure			

## SANDWICH REGULATOR FOR ISO 2 VALVES

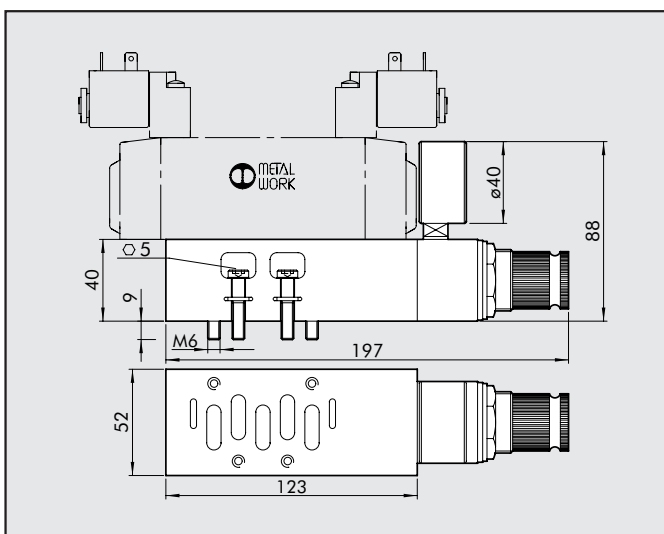

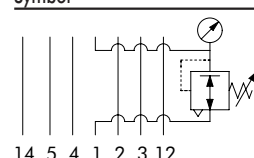
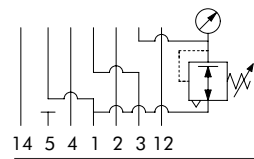
Symbol	Code	Description	Weight [g]
	0228001804	Sandwich regulator 1 0 ÷ 12 bar ISO 2	900
	0228001814*	Sandwich regulator 3 0 ÷ 12 bar ISO 2	900
*A pilot-assisted valve needs to be used since port 1 relieves pressure, it is not under pressure			

METAL WORK S.p.A

Head office: Via Segni, 5-7-9 25062 - Concesio (Brescia) Italy - Tel. 030 21 87 11 - Fax 030 21 80 569  
www.metalwork.it - metalwork@metalwork.it

The dimensions shown in this catalogue are subject to variations at any time without prior notice