

# ISO 5599/1阀 ISV系列电磁阀，带M12接口

技术参数	ISO 1	ISO 2
工作压力		
• 单电控	2.5 - 10 bar	
• 双电控	1 - 10 bar	
• 外先导型	真空 - 10 bar	
最小外先导压力	2.5 bar	
工作温度	-10° - +60°C	
公称口径	7.5 mm	12 mm
声速流导 C	250 NI/min · bar	657.14 NI/min · bar
临界压力比 b	0.36 bar/bar	0.25 bar/bar
6 Bar ΔP 0.5 Bar 时的流量	700 NI/min	1800 NI/min
6 Bar ΔP 1 Bar 时的流量	1100 NI/min	2700 NI/min
切换时间单电控 (6 Bar 时)	22 ms / 60 ms	78 ms / 180 ms
电磁先导:	在线圈内部	
手控:	双稳态: 在电磁先导导体上 单稳态: 在阀体上	
线圈功耗:	1,2 W	
电压	24 VDC ±10%	
电接口	M12	
防护等级	IP65 EN60529	
电子保护	二极管	



2

## 5/2 ISO 1 单电控

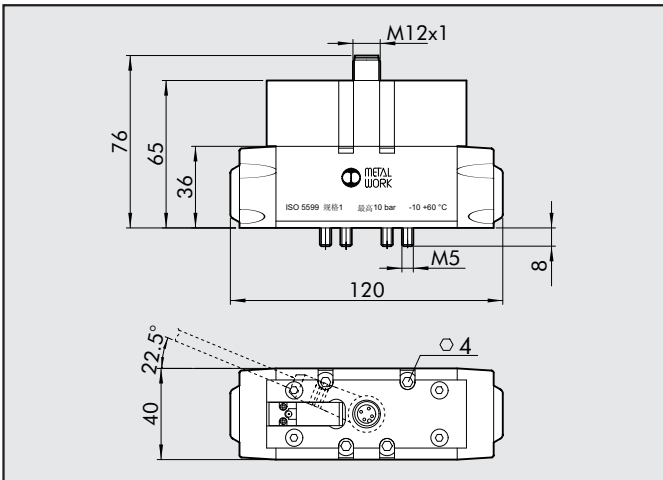

符号	缩写	代号	重量[g]
	ISV 55 COS OO	7054021100	508
	ISV 55 CES OO	7054021400	508



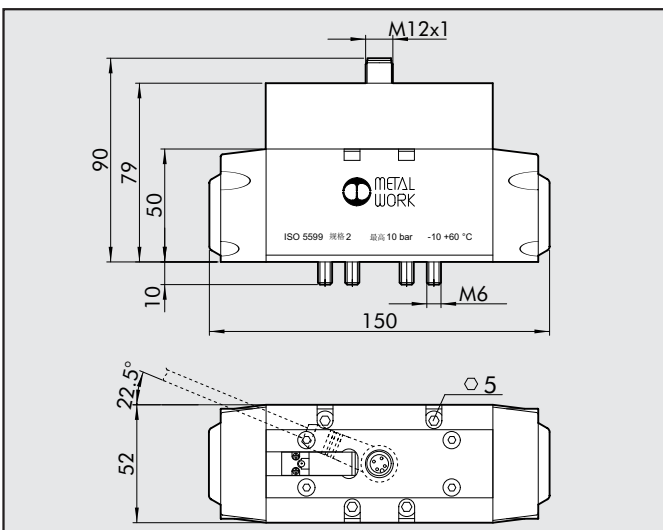



## 5/2 ISO 2 单电控

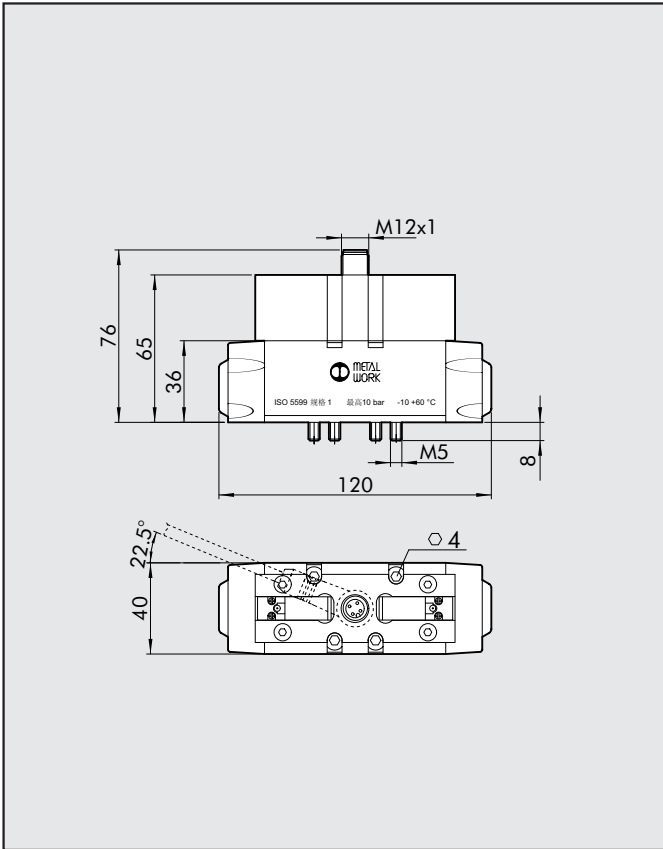

符号	缩写	代号	重量[g]
	ISV 65 COS OO	7055021100	901
	ISV 65 CES OO	7055021400	901

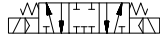
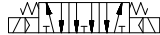
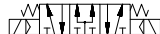

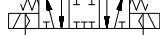

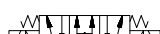

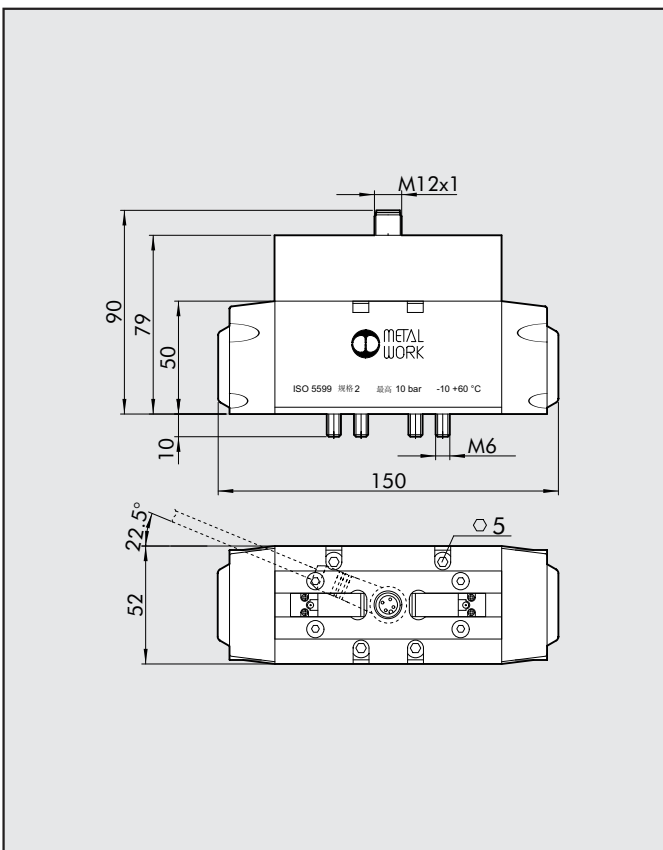

5/2 ISO 1 双电控, 5/3 ISO 1

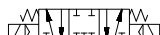

符号	缩写	代号	重量 [g]
	ISV 55 COB OO	7054021200	512
	ISV 55 COD OO	7054021300	490
	ISV 56 COS CC	7054022100	496
	ISV 56 COS OC	7054022200	496
	ISV 56 COS PC	7054022300	496
	ISV 55 CEB OO	7054021500	512
	ISV 55 CED OO	7054021600	490
	ISV 56 CES CC	7054022400	496
	ISV 56 CES OC	7054022500	496
	ISV 56 CES PC	7054022600	496

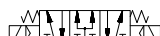
5/2 ISO 2 双电控, 5/3 ISO 2

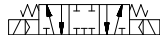

符号	缩写	代号	重量 [g]
	ISV 65 COB OO	7055021200	860
	ISV 65 COD OO	7055021300	860
	ISV 66 COS CC	7055022100	868
	ISV 66 COS OC	7055022200	868
	ISV 66 COS PC	7055022300	868
	ISV 65 CEB OO	7055021500	860
	ISV 65 CED OO	7055021600	860
	ISV 66 CES CC	7055022400	868
	ISV 66 CES OC	7055022500	868
	ISV 66 CES PC	7055022600	868

